

---

## Windjammer SS/IV/V Mounting Instructions **HONDA** 1981 GL-500

---

### *warning*

---

THE HARDWARE DESCRIBED IN THIS MANUAL WAS DESIGNED TO MOUNT THIS WINDJAMMER SS/IV/V FAIRING TO THE MOTORCYCLE(S) DESIGNATED.

---

If you are unable to determine if this hardware is for your motorcycle, contact your dealer. If your dealer is unavailable, contact the Vetter Corporation Customer Service Department, Rantoul, IL 61866, (217) 893-9300. These instructions contain valuable information for future reference. They must be given to the customer.

### *note:*

This manual may cover several motorcycles and some illustration details may differ from yours. Follow the instructions.

---

## Prepare for Fairing Installation

---

1. Put the motorcycle on its center stand. Remove the seat and gas tank to prevent damage and facilitate assembly.
2. Remove the two phillips head screws, holding the headlight nacelle and remove the headlight.
3. Disconnect the wiring block connectors and bullet connector located in the nacelle. Remove the two bolts holding the nacelle to the stays and pull the nacelle off, pushing the wires out the back.
4. Remove the plastic horn cover on the lower triple clamp and remove the two bolts holding the horns. Remove the horns and the horn bracket from the lower triple clamp. (illus. 1)

5. Remove the lower triple clamp bolt and 8mm bolt holding the turnsignal assemblies. Remove the turnsignals and replace the lower triple clamp bolt. Tighten to factory specifications. (Illus. 1)

6. Disconnect the tachometer and speedometer cable at the instruments.

7. Remove the two 6mm nuts holding the headlight bracket to the instrument panel studs. Lift the instruments up slightly and remove the headlight bracket by pulling it forward and up. (Illus. 2)

8. Remove the rubber grommets from the top of the headlight bracket. Fit the grommets, washer side down, to the instrument panel studs and secure with the original washers and nuts. (Illus. 3)

9. Install the horns on the lower triple clamp as shown, using the original bolts. Locate the brake line and wiring behind the horns and tighten the bolts. (Illus. 3)

①

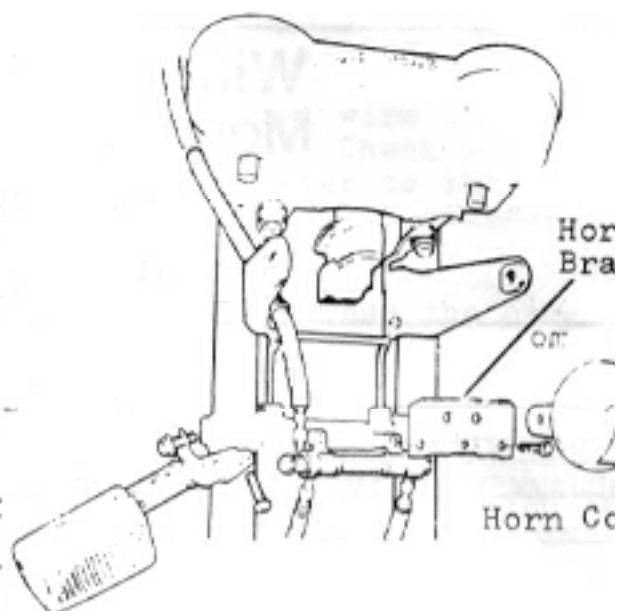

②

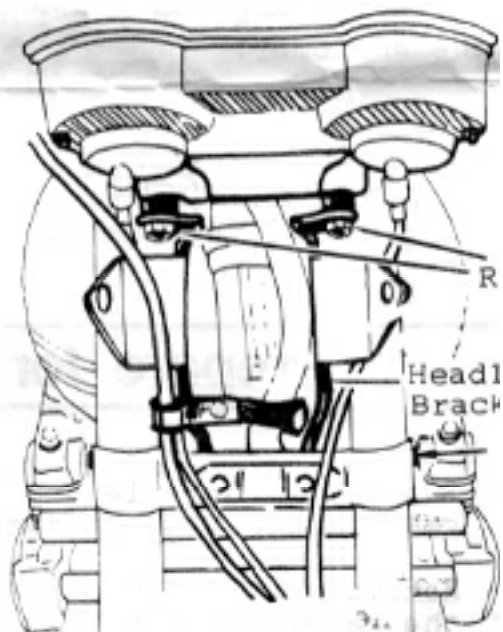

③

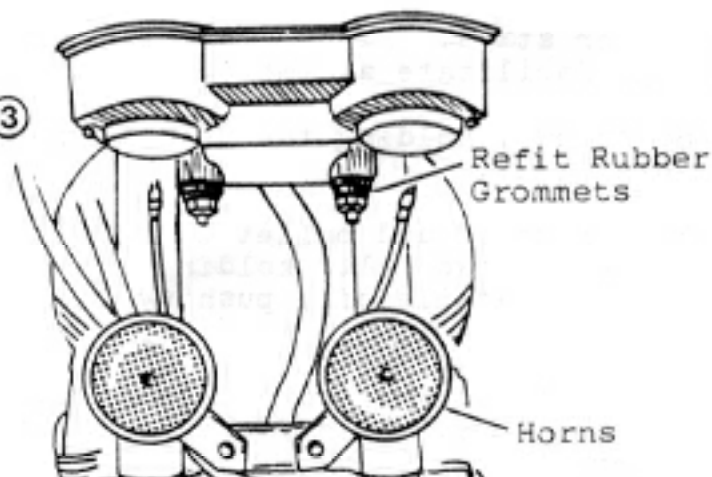

## Electrical Connections

1. Refit all the wiring block connectors to their original counterparts.
2. Route the Vetter wiring harness between the frame and left fork tube. Attach the 3-prong plug in the harness to the motorcycle's headlight socket.
3. Connect the remaining wires following the color code below:

Fairing Wire	Function	Bike Wire
White.....	high beam.....	Dark Blue
Yellow.....	low beam.....	White
Black.....	ground.....	Green
Violet.....	left turnsignal.....	Orange
Blue.....	right turnsignal.....	Light Blue
Green.....	running lights.....	Brown/White
Red.....	cigarette lighter.....	White/Green
Brown.....	accessory (horn option).....	Battery
Orange.....	accessory (horn option).....	Light Green

### **caution**

THE ORANGE, BROWN, AND RED FAIRING WIRES ARE CONNECTED AS ACCESSORIES ONLY FOR THE ACCESSORIES LISTED. ANY UNUSED WIRING SHOULD BE TAPED OFF AT THE END WITH ELECTRICAL TAPE. BEFORE USING THE FAIRING WIRES FOR ANY OTHER ACCESSORIES, MAKE SURE YOUR MOTORCYCLE'S ELECTRICAL SYSTEM WILL TOLERATE THE EXTRA CURRENT DEMAND.

Plug the male bullets into the appropriate female connectors. Gently pull all connectors to make sure they are tight. If not, crimp the outside of the connectors with wire crimpers or pliers after the connection is made. (Illus. 4)

For wires without connectors, use the provided blue connectors as shown.

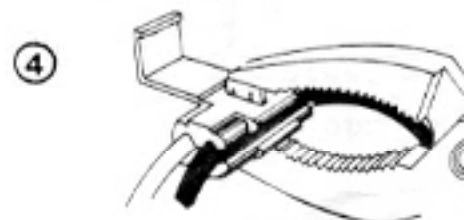
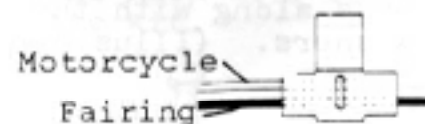

- Snap the blue connector over the appropriate motorcycle wire.
  - Insert the appropriate fairing wire into the other hole. The wire will not go all the way through the connector.
  - Squeeze the metal tab down flush with the top of the connector.
  - Fold the plastic lid down and snap it shut.
4. Cover all the wiring connectors with the black vinyl bag supplied. Cinch up the drawstring and place the bag upside down to keep water out. Hook two ty-raps end to end and secure the bag to the wire harness going into the instrument panel.

---

## Install Mounting Bracket

---

**note:** For detailed information on the use of engine guards with this hardware, consult page 5 of your Fairing Owner's

1. Remove the four phillips head screws on each side holding the radiator shrouds and remove both shroud sides.
2. Remove the forward engine mount nuts along with the spacer and washers. (illus. 5)

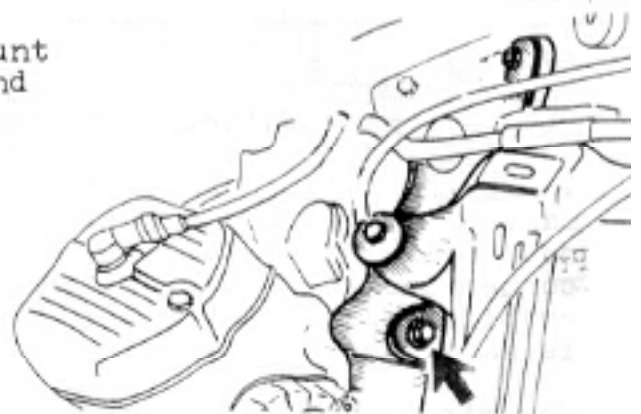

3. Position the bracket on the frame and install the supplied 8x110mm bolt, flat washers, spacers and locknut on the upper frame. (Illus. 6)
4. Install the 8mm locknuts and washers on the forward engine mount.
5. Tighten the upper frame bolt and then the engine mount bolts.
6. Reinstall the radiator shrouds by installing them from the top between the bracket and the radiator.
7. Reinstall the four phillips head screws in the shroud and tighten securely.

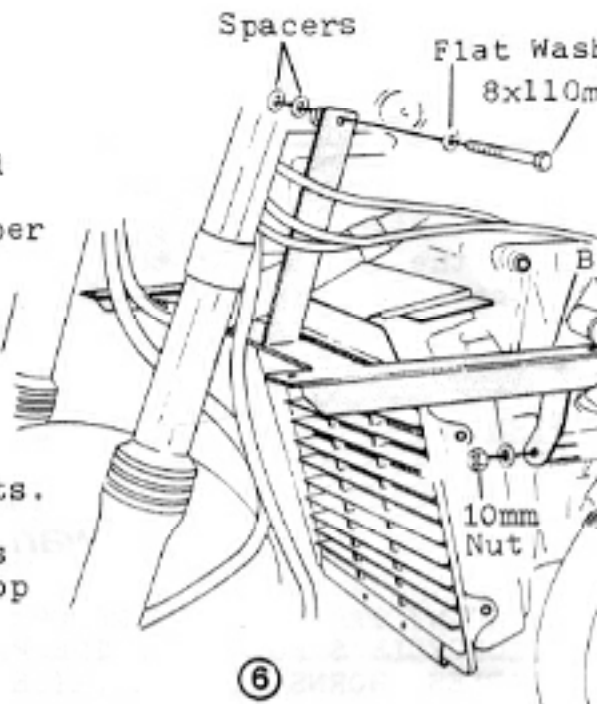

## Mount the Fairing

### **WJ SS/IV only:**

If you are planning to install optional Vetter cold inserts, they should be applied before the fairing mounted.

**note:** If you are installing the optional horn kit, refer the instructions packaged with the kit.

1. Prepare the four 6x35mm bolts with the steel and neoprene washers as shown. (Illus. 7)
2. Set the fairing on the mounting bracket and secure it with the prepared bolts and four locknuts.

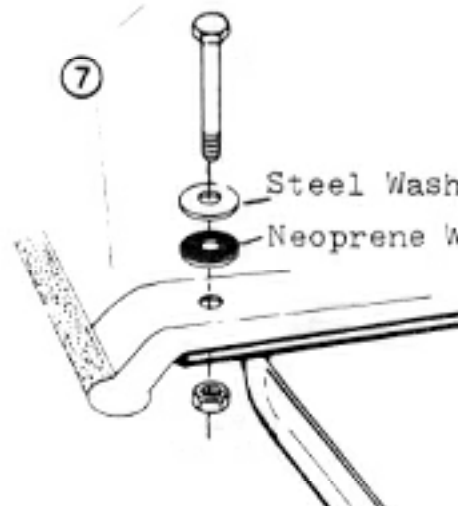

3. Before tightening the nuts, plug the external wire harness into the fairing at the serial number plate. Check all electrical components before continuing. Refer to the Troubleshooting section of your Owner's Manual if problems arise.
4. Tighten the four nuts enough to slightly compress the neoprene washers.

---

***warning***

---

AFTER INSTALLATION, THE FAIRING OR BRACKET MUST NOT INTERFERE WITH ANY PART OF YOUR MOTORCYCLE. CHECK THE AREA BETWEEN YOUR MOTORCYCLE'S FORKS AND THE FAIRING FOR CONTACT AT ANY POINT (CABLES, HORNS, ETC.), WHILE TURNING THE HANDLEBARS COMPLETELY FROM SIDE TO SIDE.

---

Refer to your Owner's Manual for windshield mounting instructions and final adjustments. We suggest you insert these instructions in the Owner's Manual for future reference.

USE THIS SCALE TO CHECK BOLT AND WASHER DIMENSIONS

