

EG 3170

# Floating Mount Saddle Bags

## Mounting Instructions and Owner's Manual

**Honda GL-1000  
GOLD WING**

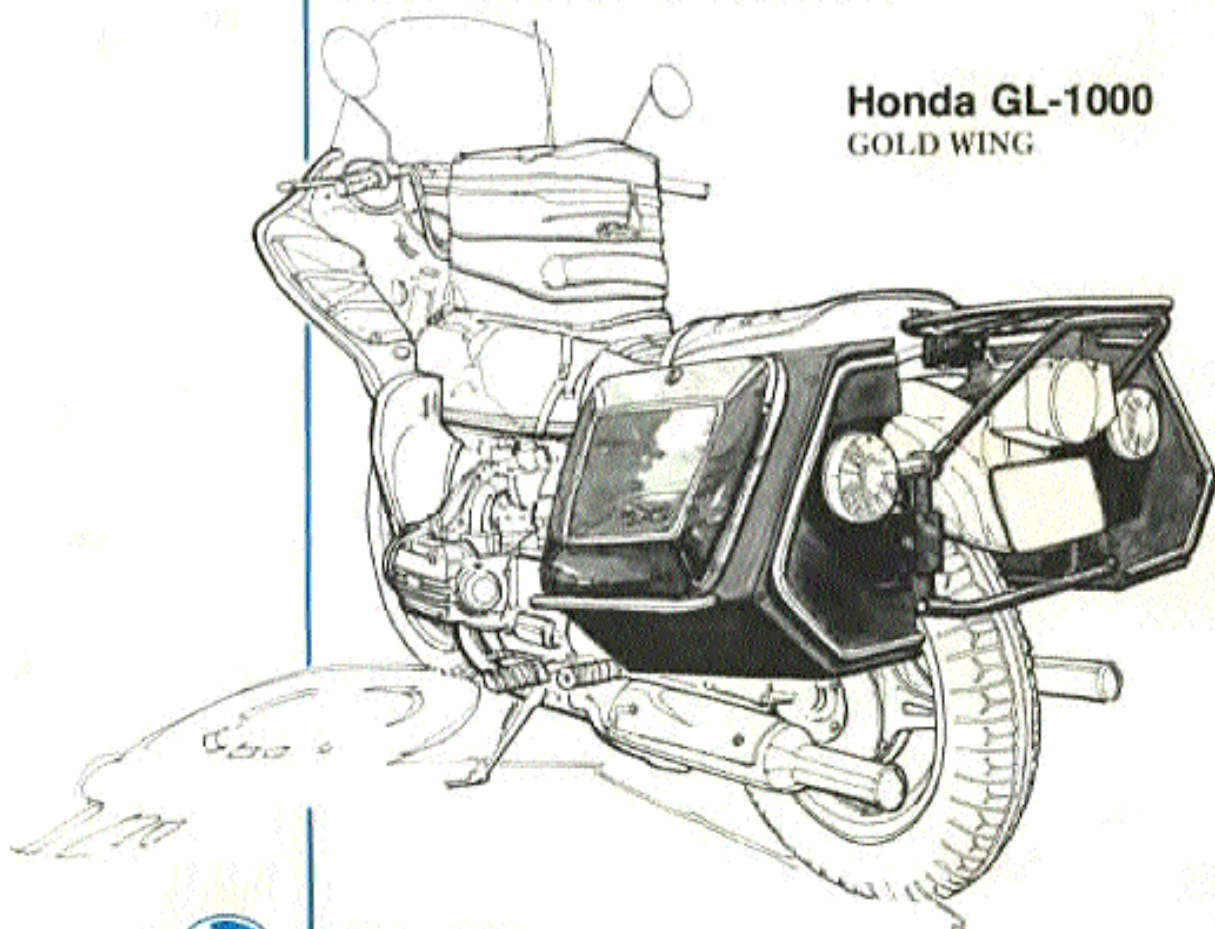

**Vetter**  
Vetter Fairing Company  
Holland, Michigan 49424 217-863-9300

© Copyright  
Vetter Fairing Company  
January 18, 1978

# Table of Contents

INTRODUCTION . . . . .	2
PREPARATION FOR HARDWARE MOUNTING . . . . .	3-7
HARDWARE PARTS NOMENCLATURE . . . . .	8
INSTALLING THE HARDWARE . . . . .	9-12
SADDLE BAG PARTS NOMENCLATURE . . . . .	13
SADDLE BAG DOOR MOUNTING . . . . .	13-15
SADDLE BAG MOUNTING . . . . .	15-16
CARRYING THE SADDLE BAGS . . . . .	17
MAINTENANCE . . . . .	18
CUSTOMER SERVICE . . . . .	18
WARRANTY . . . . .	18

**SPECIAL NOTE:** To comply with federal legislation, this manual must be given to the consumer. It contains their copy of the limited Warranty and can be useful for their future reference.

This manual contains important information regarding the proper installation, safe operation and maintenance of your Floating Mount Saddle Bags. While it may appear lengthy, we urge you to read it completely, understand all components of your Saddle Bags and Floating Mount Hardware and follow the recommendations to obtain the most trouble-free and enjoyable operation.

In this manual, statements preceded by the following words are of special significance:

**WARNING** — means that there is the possibility of injury to yourself and others.

**CAUTION** — means that there is the possibility of damage to the saddle bags and related components.

**NOTE** — indicates points of particular interest for more efficient and convenient installation and operation.

We recommend that you take particular notice of these items when reading this manual.

The intent of this manual is to insure that your Floating Mount Saddle Bags are properly installed — PLEASE USE IT! First, we recommend that as you unpack your saddle bags, use the hardware parts nomenclature guide and saddle bag parts nomenclature guide (found in the table of contents) to study and recognize the various parts, so you will understand the detailed assembly steps that follow. Working straight through the manual will assure that nothing is overlooked or forgotten. If you wish to stop at any point during

People have continually asked me "Why don't you build some good saddle bags?" Well, in the past, building Windjammers has been totally consuming. But now, with our new facility in San Luis Obispo, CA, we have the time and place to do new things.

For some time now, all of our talent and resources has been devoted to designing and engineering rear luggage that is as

the installation of your saddle bags, do so at the end of an assembly step.

**CAUTION:** Follow the assembly steps in their correct order. Completely finish one step before proceeding to the next assembly step.

This manual is broken into three major sections: Preparation for Hardware Mounting, Installation of Hardware and Saddle Bag Door Mounting & Saddle Bag Mounting. In the first section, Preparation for Hardware Mounting, you will prepare your motorcycle for the saddle bag hardware by disconnecting or removing some of your motorcycle's parts. Some of these original parts will be reused and others will not. The second section deals with actually installing the Floating Mount Hardware on your motorcycle. Use all of the indicated hardware in the order shown. In the third and final section you will be instructed on how to complete assembly of your saddle bags and mount them on your motorcycle.

As you are following the instructions, double check the following points, as they are critical:

1. Carefully check wiring color codes.
2. If you have safety bars, check carefully to determine if they are compatible with the saddle bag mounting system.
3. Check for clearance and tighten all bolts before operating your motorcycle with the newly installed saddle bags and hardware.
4. Periodically check and retighten all bolts and clamps after installation.

good as our Windjammer. In fact, in many ways it's more advanced.

Considering what other saddle bags are like today, I think you will agree that our Floating Mount Luggage is the first to do it right.

  
Craig Vetter  
Designer  
San Luis Obispo, CA.

## Introduction

## Note from Craig Vetter

## Preparation for Hardware Mounting **GL-1000**

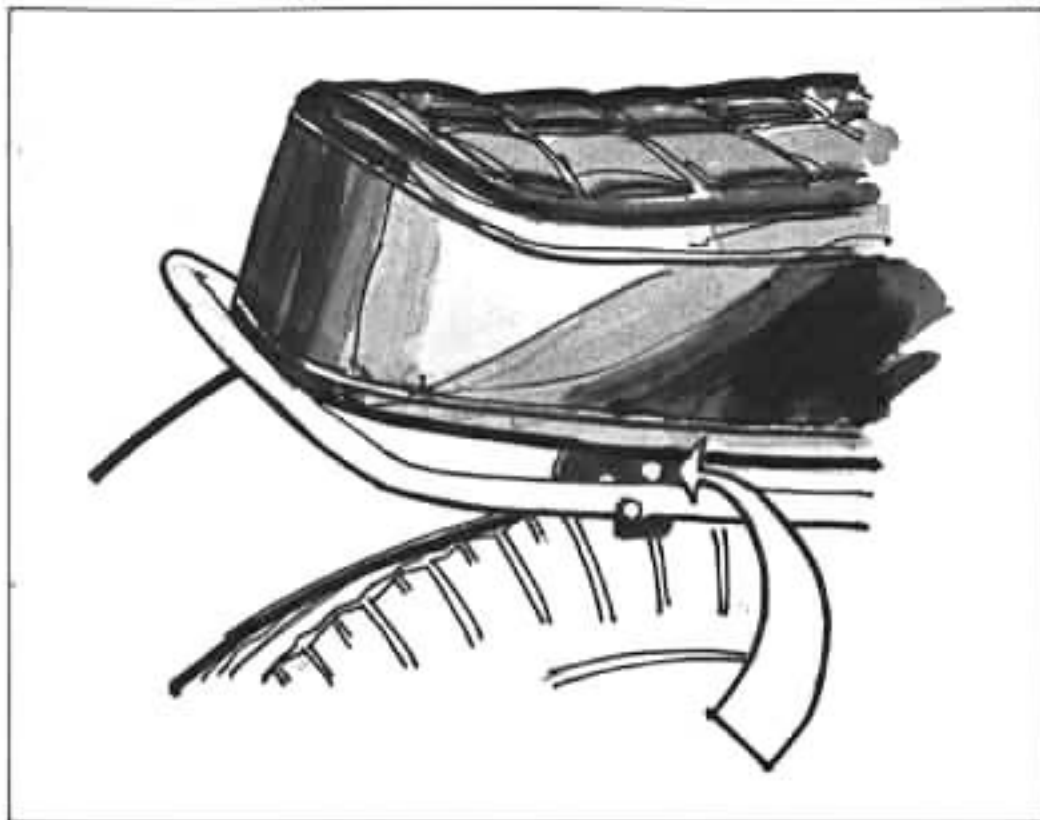

### Objective

Installation of the Floa Mount Saddle Bag hard may require the disasse and/or removal of your motorcycle's turnsignal grab bar mounts, passer footrests and seat.

### Removing the seat mounting bolts

Remove the bolts with washers (one of each or side) which secure the s to the frame. Use a 12n wrench.

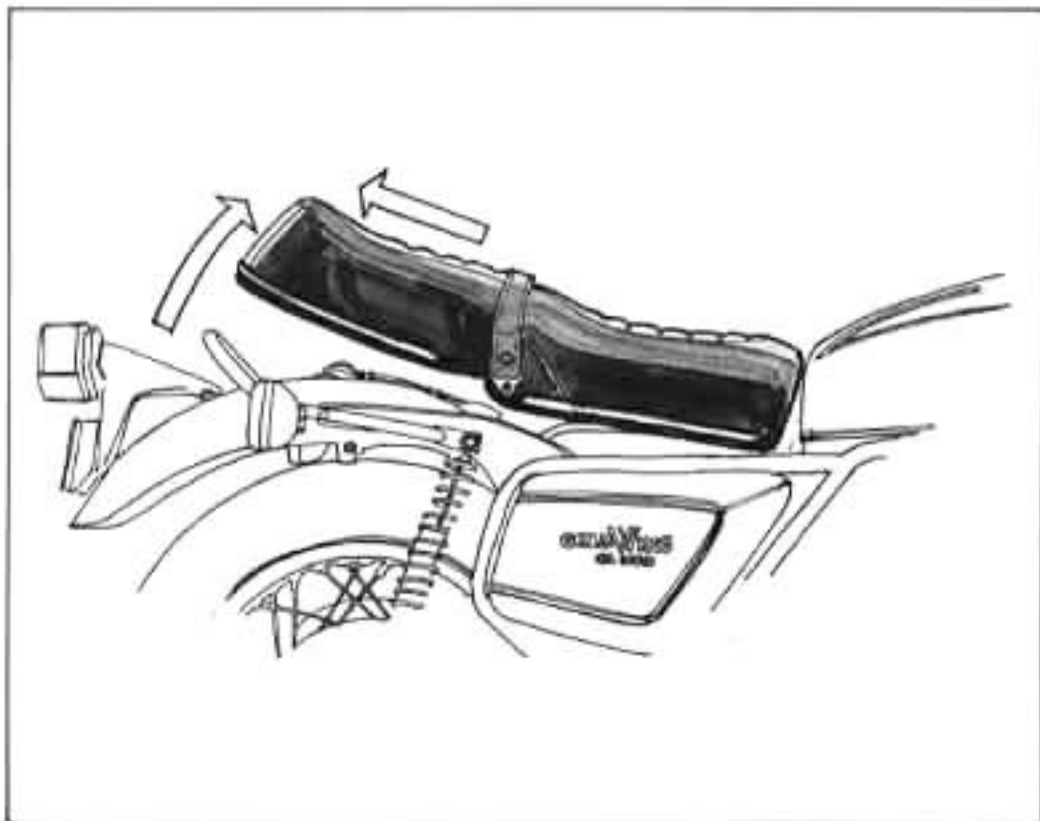

### Removing the seat

Pull the seat slightly up rear and back towards t of the motorcycle. This disengage the seat from forward mount.

# 3

### Disconnect turnsignal wiring at connector (1978 model)

Disconnect the orange on black and blue on black turnsignal wires at their connectors located on top of the rear fender.

Holding onto these wires from under the fender, gently pull them through the rubber grommet.

### 1977 and earlier models

Disconnect the orange on black, blue on black and two (2) green ground wires from their connectors located on top of the rear fender.

From this step go directly to step number 6 if your motorcycle is a 1977 or earlier model GL-1000.

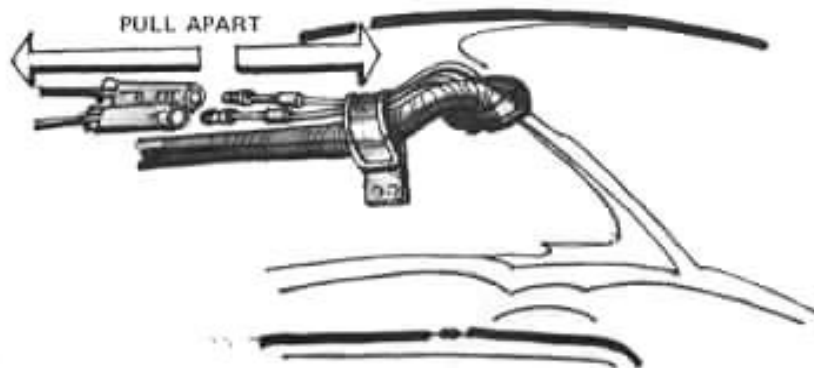

# 4

### Removing turnsignal wiring

Gripping the wires at the end of the channel, pull them through the channel. Carefully guide the wires through the opening at the top of the channel as you pull.

Remove license plate.

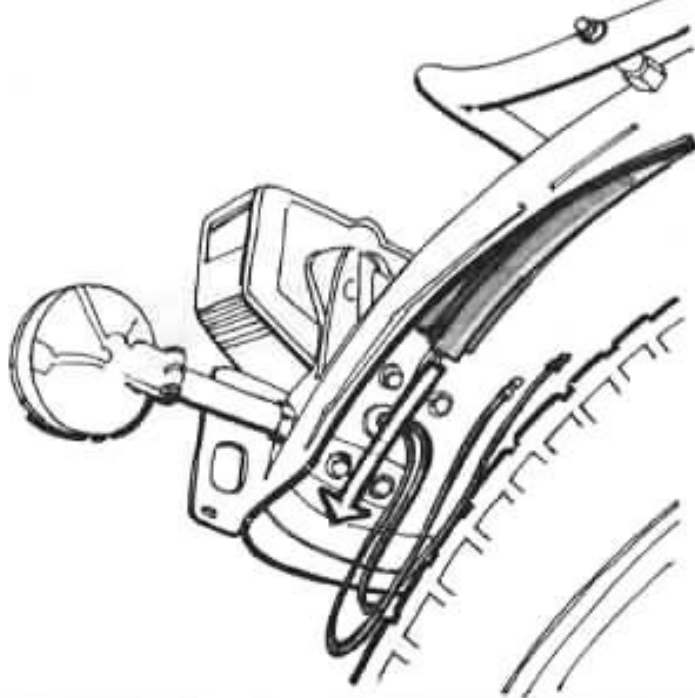

# 5

## Removing turnsignal wiring (cont.)

Finally, pull these same two wires through the rubber grommet located under the taillight/stoplight assembly.

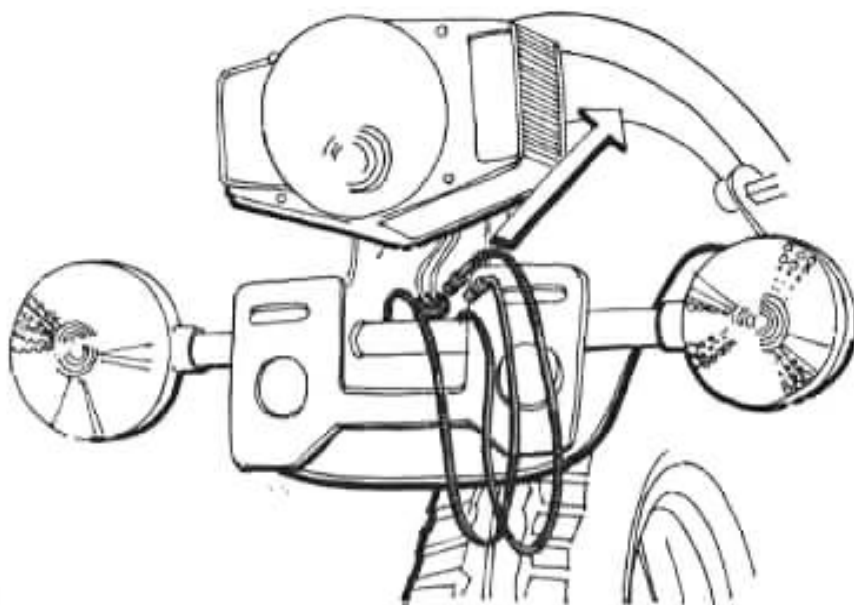

# 6

## Removing turnsignal lamp bolt

Using two 10mm wrenches, remove the bolt and nut which secure the turnsignal lamp to its stalk. The bolt must be completely removed.

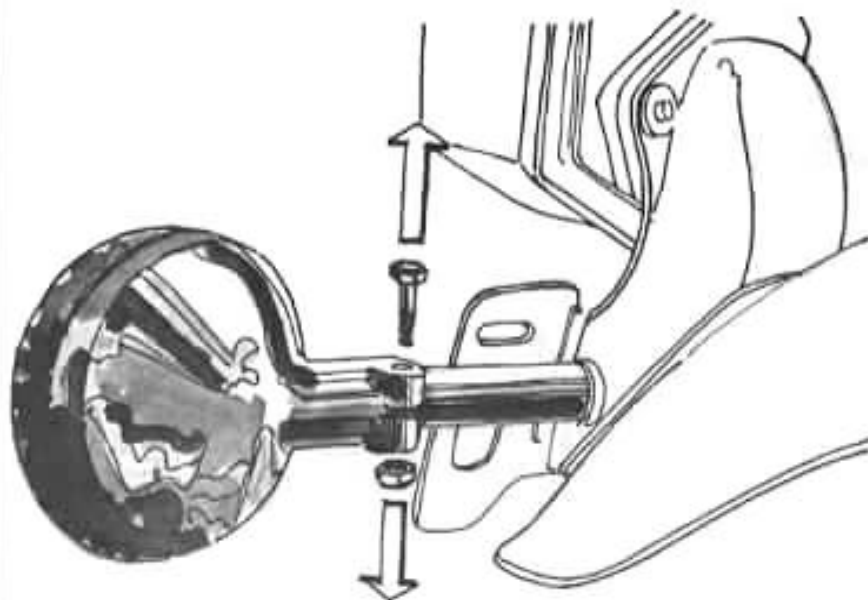

# 7

## Removing turnsignal lamp from stalk

While spreading the surface of the split on the turnsignal lamp housing with a large screwdriver, etc., pull the lamp off of the stalk and completely away from the bike while threading its wire through the stalk.

Remove the stalk with a 23mm wrench.

### 1977 and earlier models

Remove the stalk from its mount on the grab bar by removing the nut on the back side along with the green ground wire and washer.

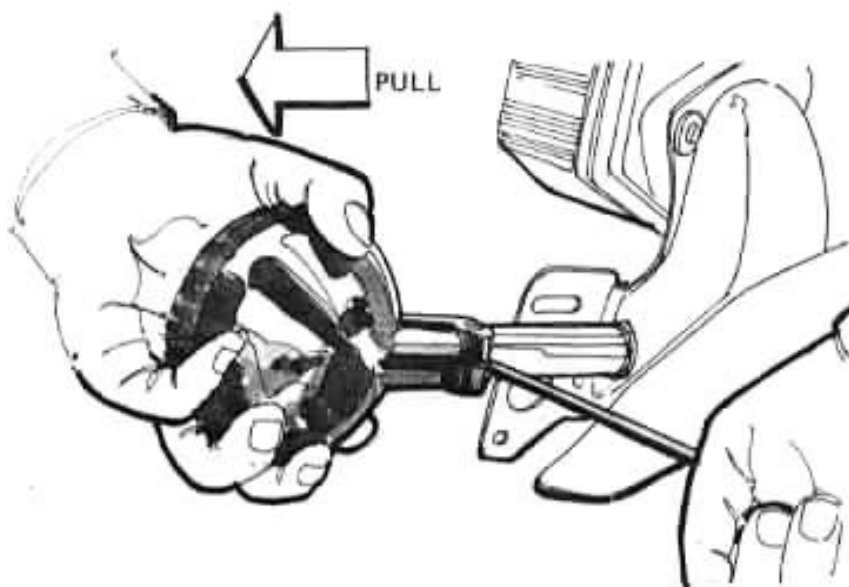

# 8

## Remove passenger footrests

Using a 14mm socket and wrench, remove the bolt and nut which hold the passenger footrests and muffler mounts to the frame. Perform this step for both sides.



**9**

**Remove grab bar mounting bolts**

Remove the bolts which secure the grab bar at the rear mounts (one on each side) with a 12mm wrench.

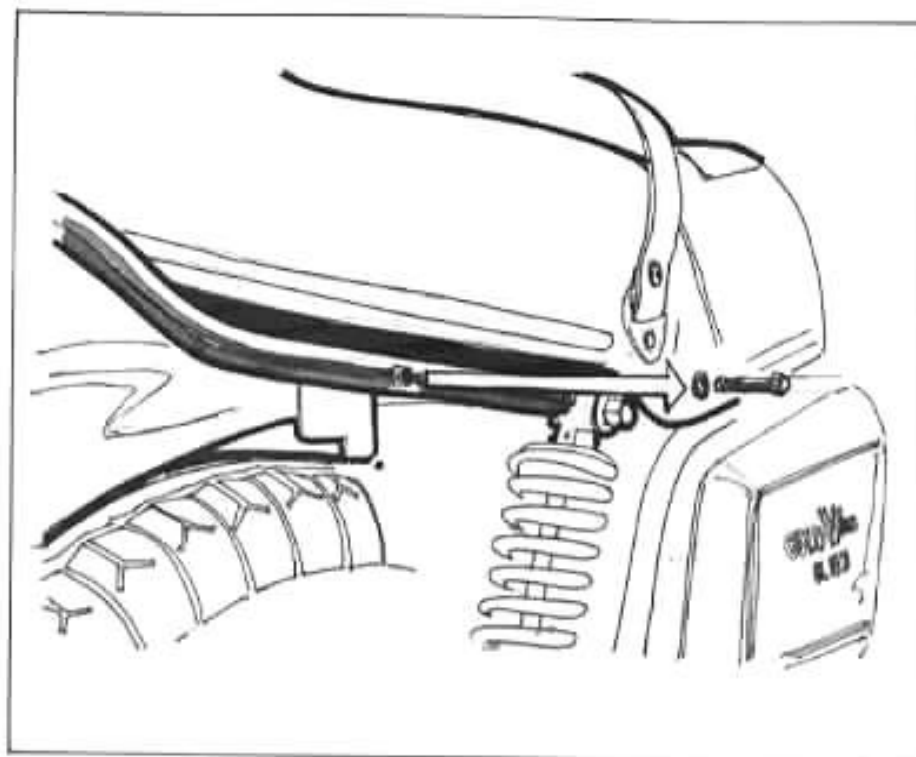

**THIS CONCLUDES THE PREPARATION OF THE MOTORCYCLE FOR MOUNTING THE FLOATING MOUNT SADDLE BAG HARDWARE.**

**PROCEED TO THE NEXT SECTION FOR HARDWARE INSTALLATION**

# Hardware Parts Nomenclature

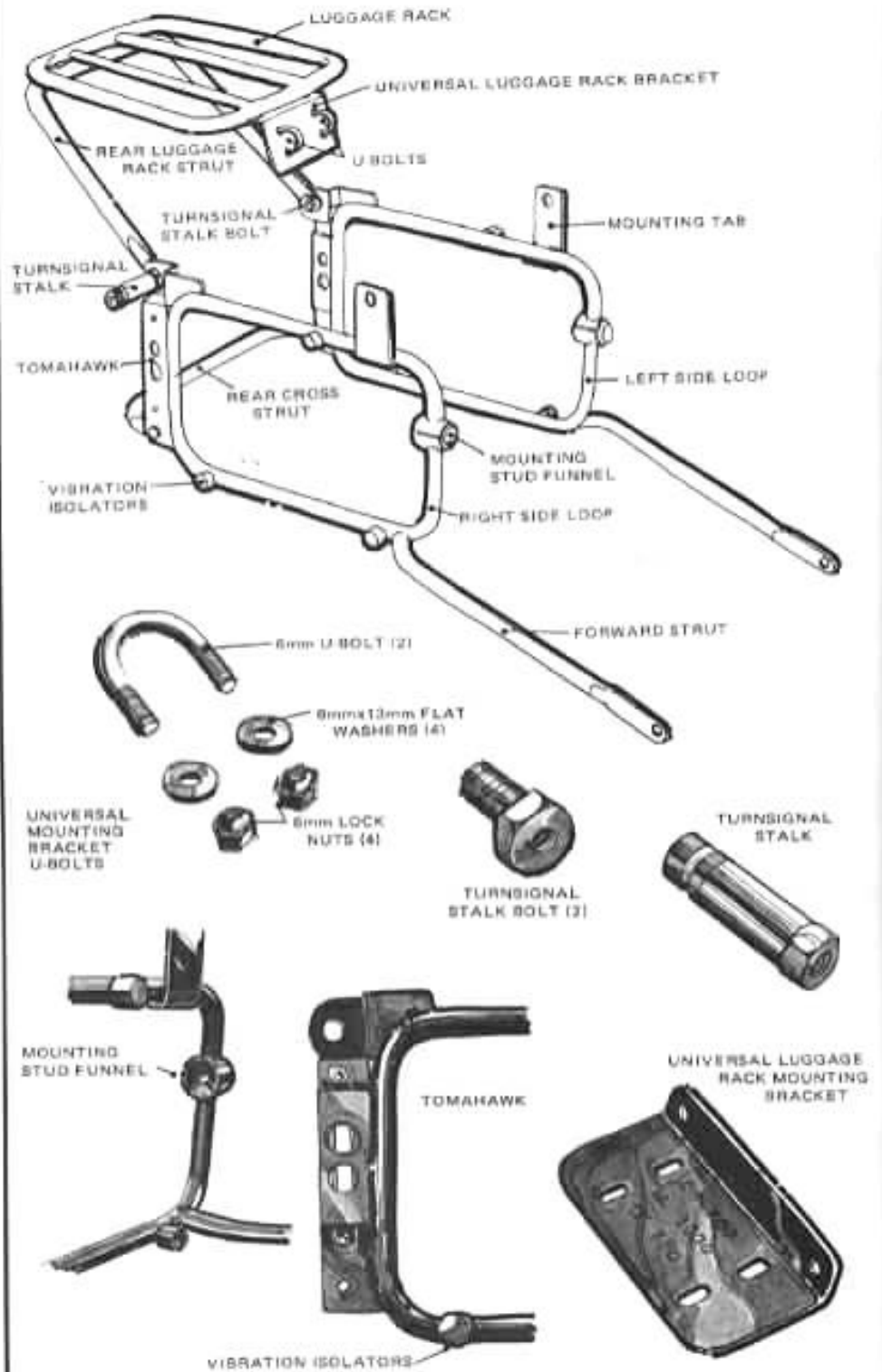

Metric Scale 1 2 3 4 5 6 7 8 9 10 11 12 13 14



## Installation of the Hardware GL-1000

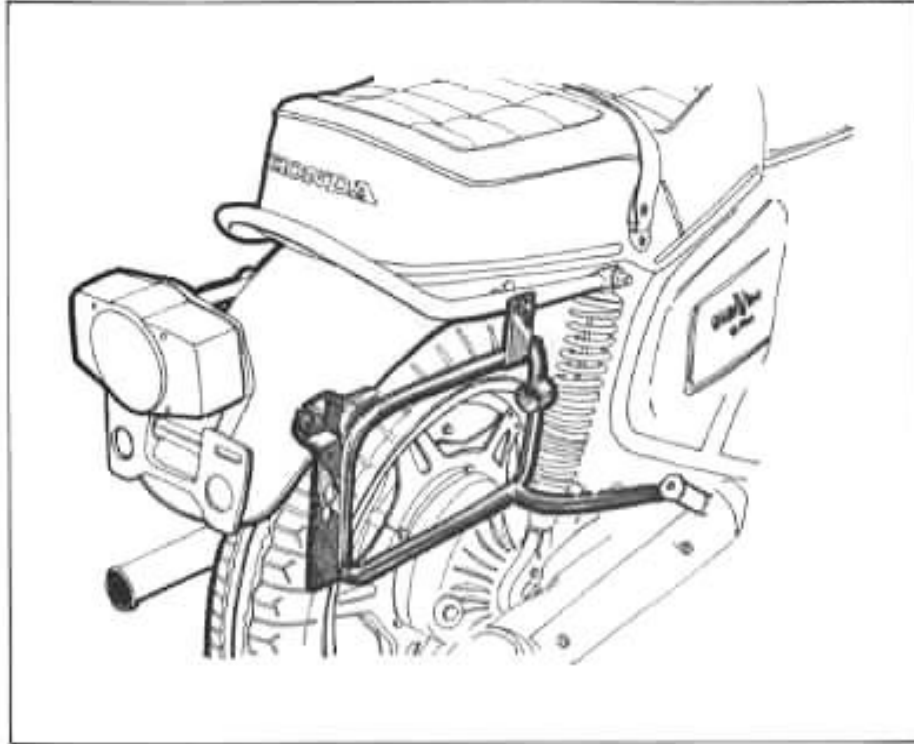

**1**

### Objective

The Floating Mount Saddle Bags are designed to fit a large number of different motorcycle models. Each model motorcycle has specially designed mounting hardware. When installed properly, the hardware will locate the saddle bags at the proper height and fore and aft location on your motorcycle. Use all of the hardware specified and periodically check for tightness after installation.

Mount the hardware for only one side at a time.

Start with either side and position the loop as shown.

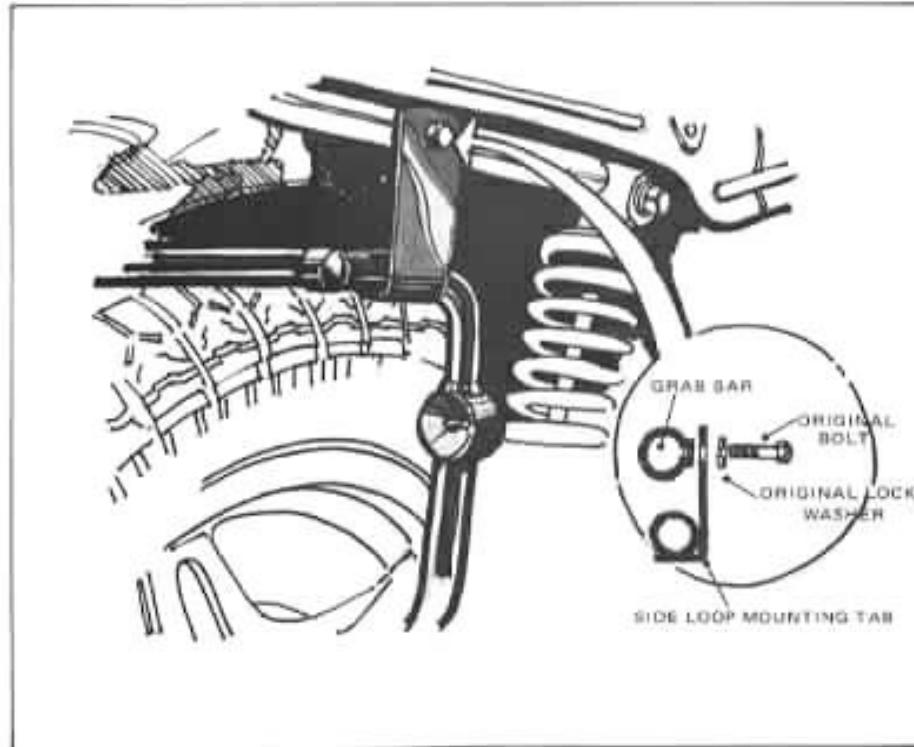

**2**

### Mounting the side loop at the grab bar mount

While holding the bracket in place, slide the bolt and lock washer, which originally held the grab bar at its rear mount, through the side loop mounting tab and into its mount. Do not tighten completely.

# 3

## Mounting the side loop at the passenger footrest/muffler mount

Using the original bolt which secured the passenger footrest to the frame, sandwich the side loop front strut between the footrest and the muffler bracket (see inset sketch for order of parts). Be sure that the tongue on the footrest engages in its corresponding hole in the muffler bracket.

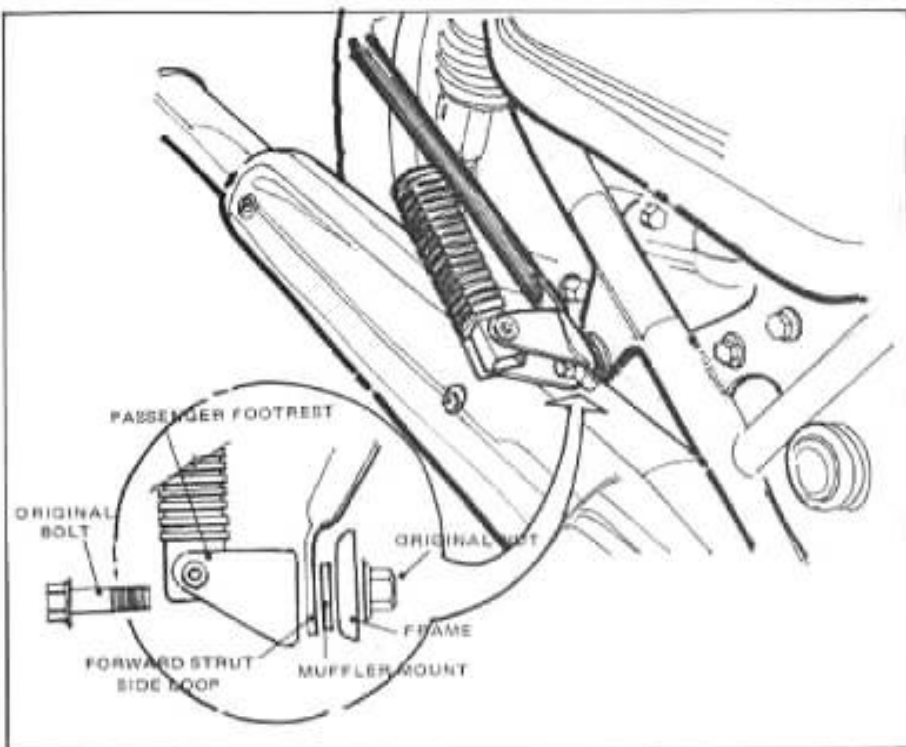

# 4

## Mounting rear strut

Locate the rear strut and secure it to the two (2) side loops tomahawks at the position shown with 2-6mm x 20mm bolts, 4-6mm x 13mm flat washers and 2-6mm lock nuts.

**NOTE:** A metric scale is supplied on Page 8 for your ease in identifying different fasteners.

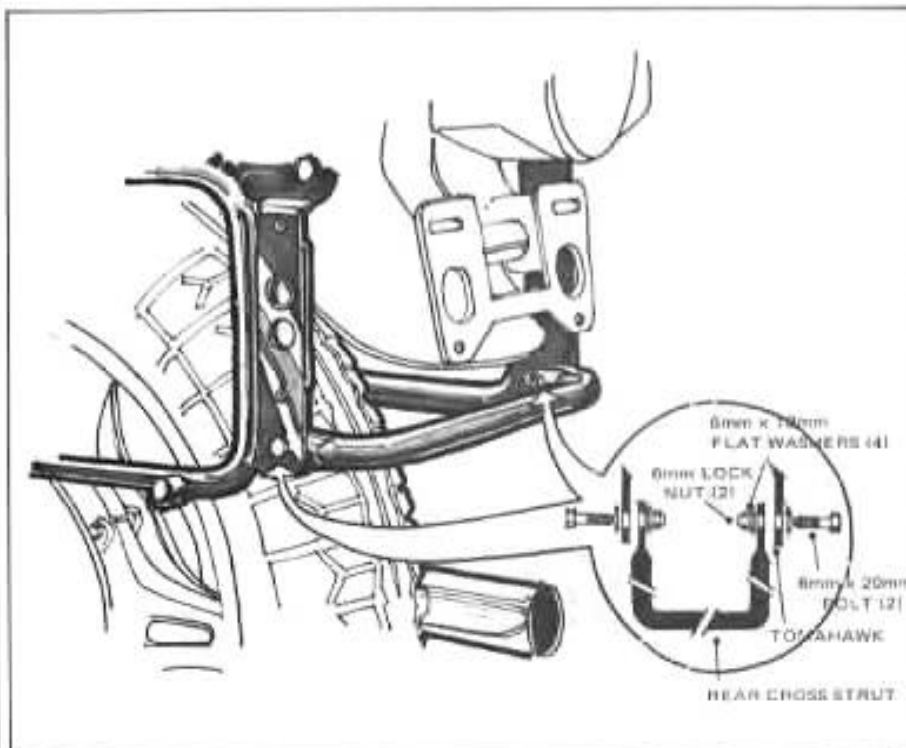

**5****Mounting rear luggage rack strut**

Locate the rear luggage rack strut and while holding it in place insert the two (2) supplied turnsignal stalk bolts through the bracket and through the side loop tomahawks.

Mount the two reflectors (supplied) at the mounting points on the rear luggage rack strut.

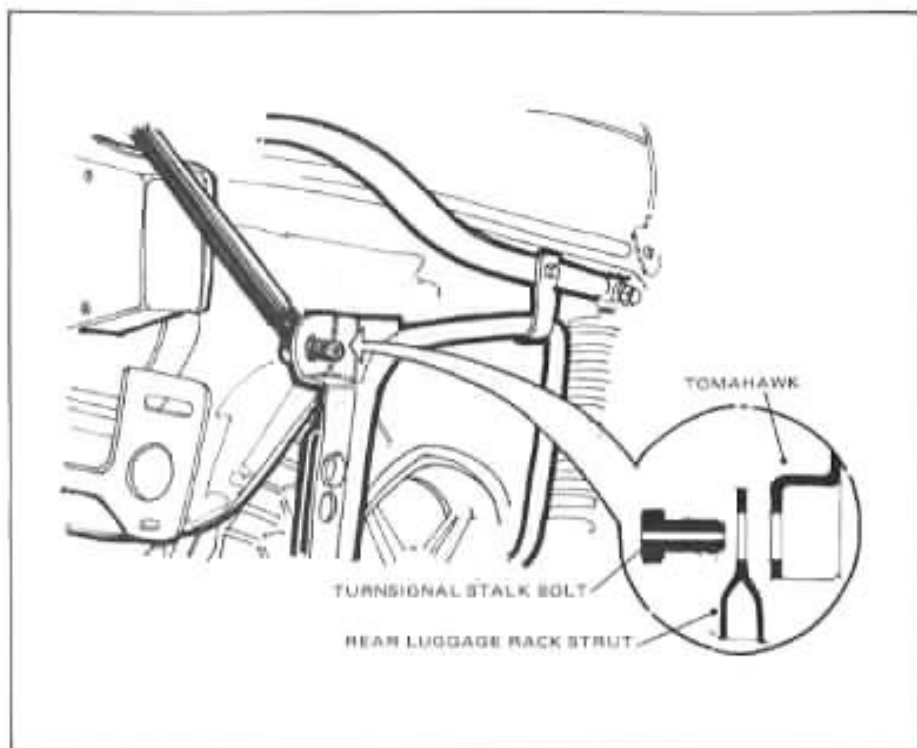
**6****Mounting turnsignal stalks**

Thread the supplied turnsignal stalks onto their bolts (installed in step 5) and tighten them enough to hold the bracket in approximately the position shown. Do not tighten completely to allow for some repositioning.

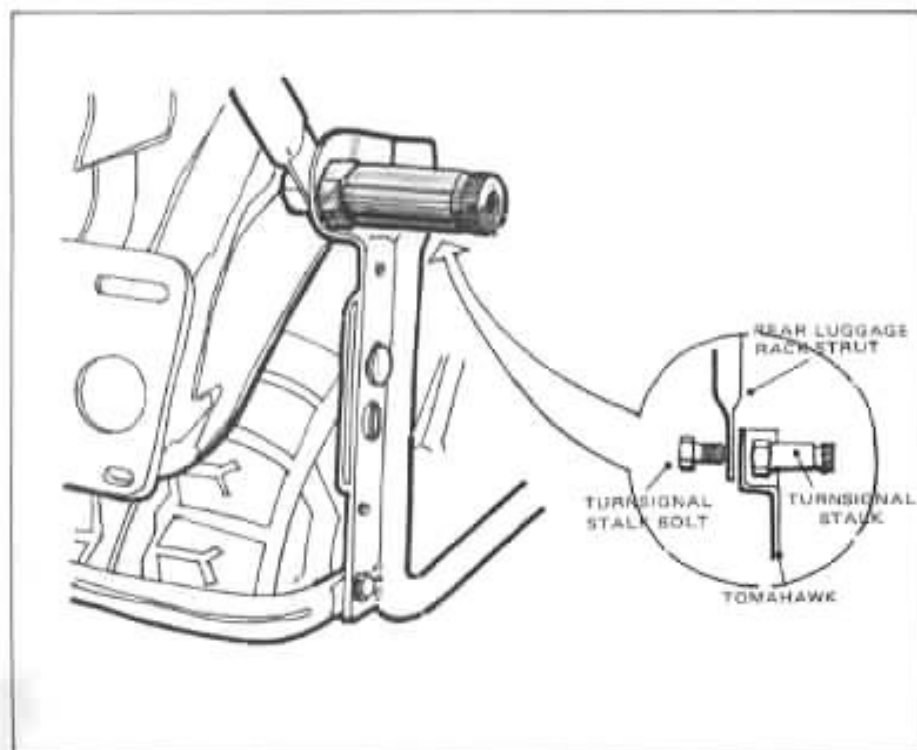

# 7

### Mount the universal luggage rack bracket

Mount the "L"-shaped universal luggage rack bracket to the luggage rack in the position shown with 2-6mm x 20mm lock bolts & 2-6mm x 13mm flat washers.

Using the 2 U-bolts, 4-6mm x 13mm flat washers & 4-6mm lock nuts, secure the luggage rack bracket to the grab bar. Do not tighten nuts completely.

**NOTE:** Perform this step with the luggage rack in a near vertical position, allowing access to the nuts.

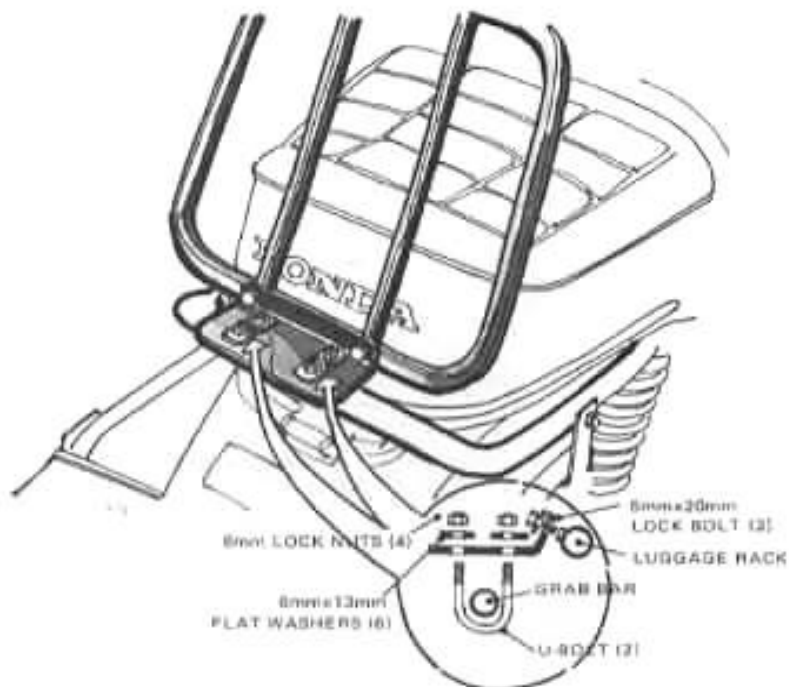

# 8

### Mount luggage rack to luggage rack rear strut

With 2-6mm x 30mm lock bolts & 2-6mm x 13mm flat washers mount the luggage rack to the rear rack strut.

### Electrical hook-up

Run the wire of each turn-signal (L-orange, R-blue) through its stalk. Reverse the procedure in steps 3, 4, 5, 6 & 7 under Preparation for Hardware Mounting. Before connecting the wires together add the 4" wire extension. Match colors and connect.

Check turnsignals for correct operation. (Refer to troubleshooting, if not.)

Remount seat.

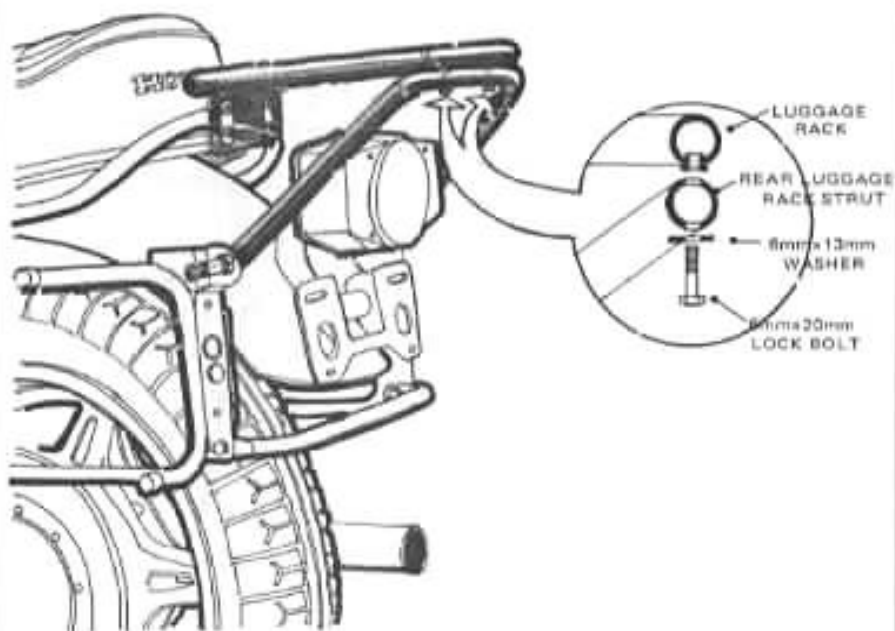

## Saddle Bag Parts Nomenclature

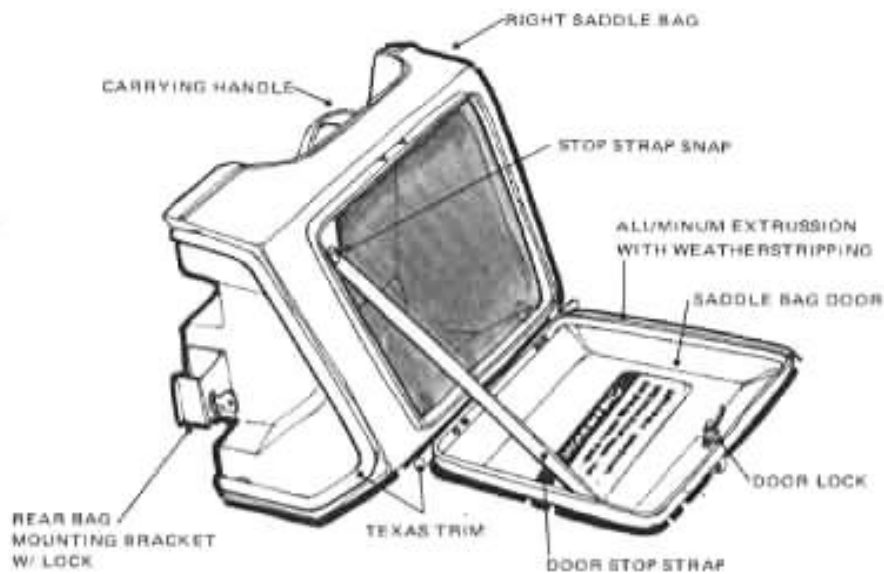

## Saddle Bag Door Mounting

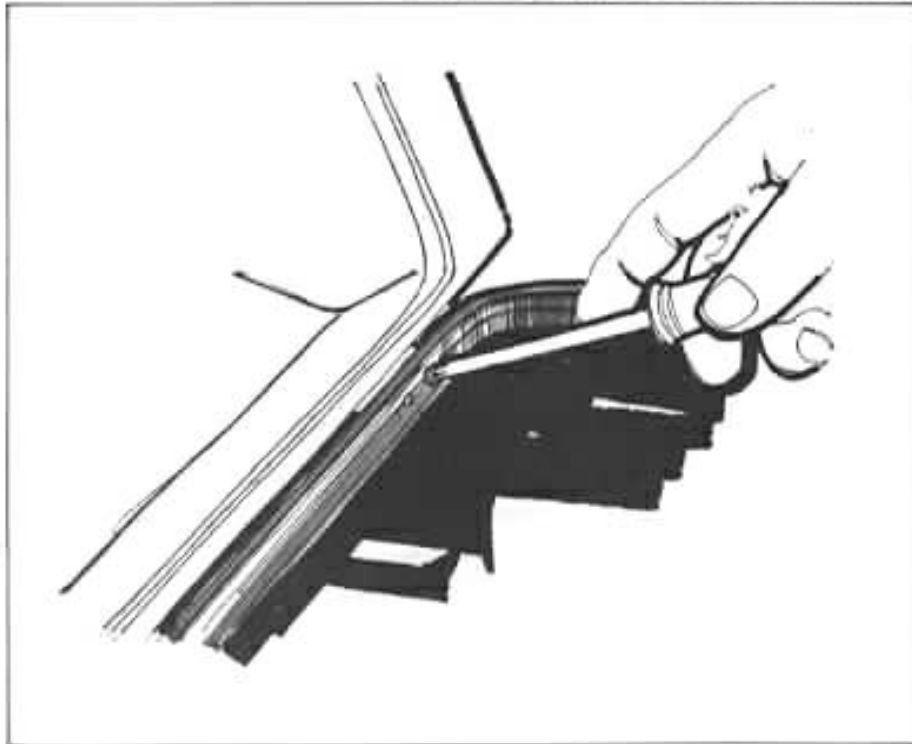

1

### Objective

In order to supply saddle bags of various colors, the doors are packaged separately and require a simple mounting procedure before the bags are ready for use.

Separate left and right saddle bags, doors & Texas Trim.

Assemble one bag at a time.

### Position door on hinges

Using 2-4mm x 12mm screws, insert one screw at each hinge point from the inside of the door. Position the door on the hinges.

# 2

**Positioning the Texas Trim**  
Next position the Texas Trim over the screws (be careful not to apply too much pressure on the screws or they will be forced into the bag).

**Thread nuts onto phillips head screws**

Now thread the 4mm lock nuts onto the screws and tighten.

Unlock the door and insert the two remaining screws through the door, hinge and Texas Trim and thread on their nuts & tighten.

Repeat the above three (3) steps for the remaining bag.

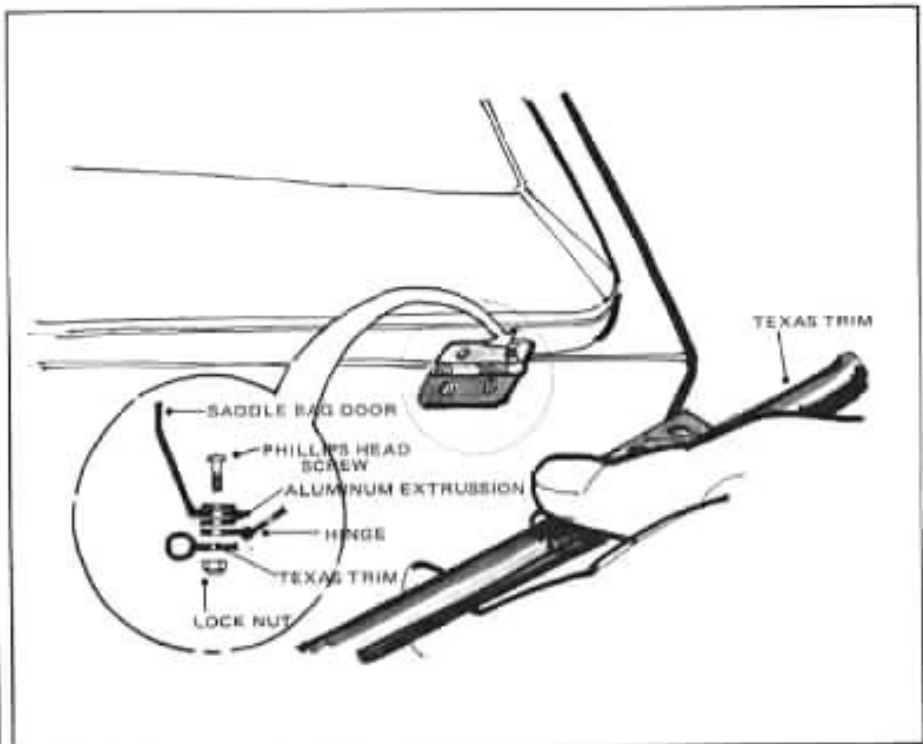

# 3

**Mounting Saddle Bag door lock**

To mount the saddle bag door lock (packaged with the bag) simply insert the lock through the door, slide on the large star washer and thread on the nut.

Mount the locking cam straight up when the key lock is in the locked position (when the key can be removed). Assemble the parts as shown.

**Mounting Texas Trim at rear of bag**

Mount the Texas Trim to each bag at 3 places with 3 black spacers, 3 nylon washers & 3 phillips head screws.

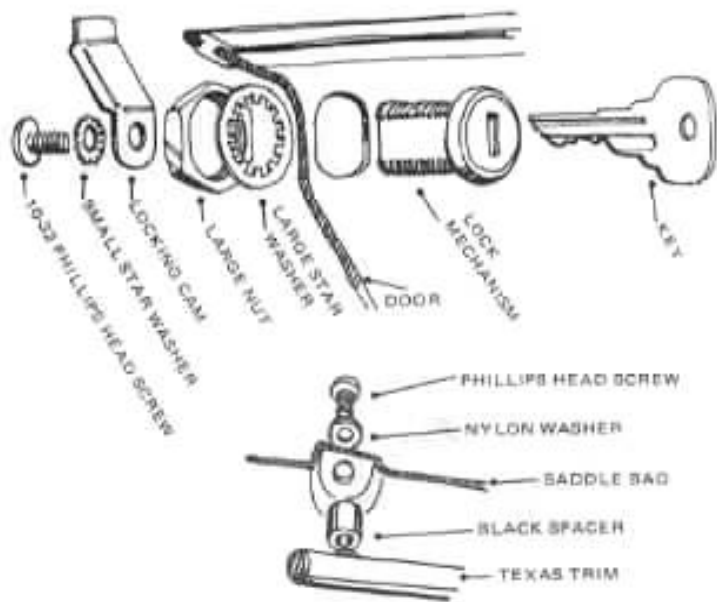

**4****Connecting snap of door stop strap**

Snap the door stop strap into position as shown.

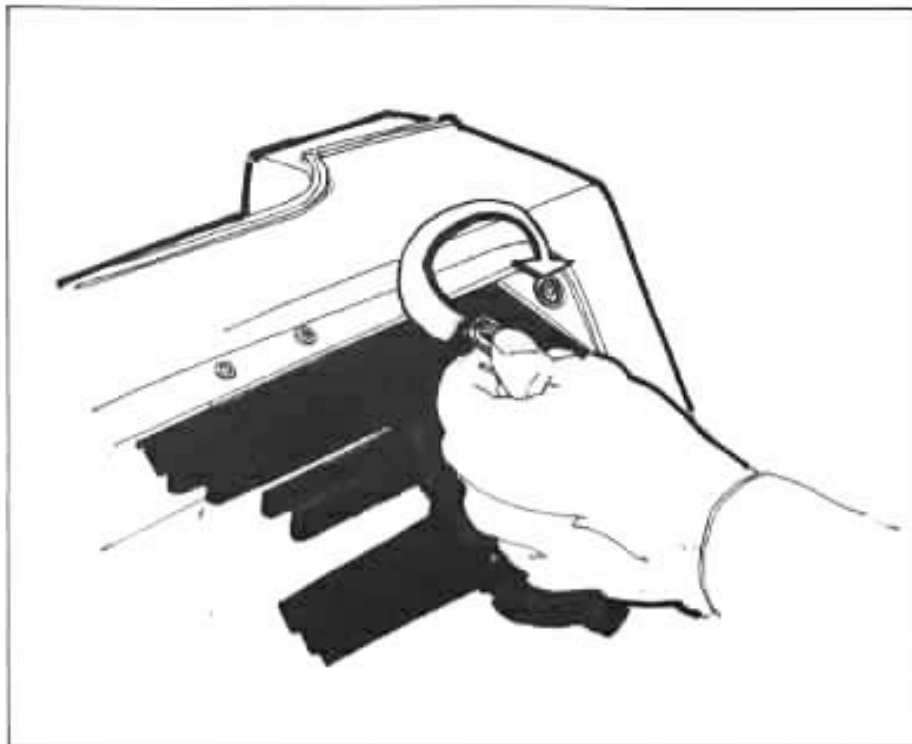
**Saddle Bag Mounting****1****Objective**

Once all of the Floating Mount Saddle Bag Hardware is attached to the motorcycle and the doors and trim are mounted on the saddle bags, the saddle bags are ready to be mounted on the motorcycle.

**Mounting the saddle bag at its forward mount**

Starting at the forward mount insert the mounting stud into the stud funnel while holding the bag out at an angle as shown.

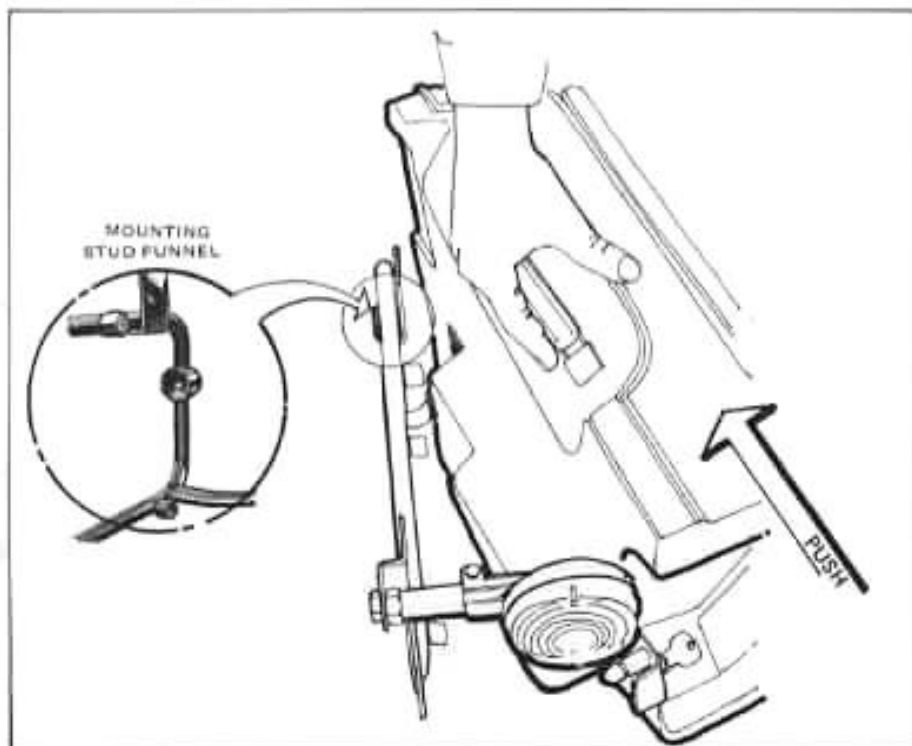

# 2

### Mounting the saddle bag at its rear mount

While holding the forward mount in position, push the rear mount of the bag to the side loop tomahawk. Insert the conehead into its spring loaded receptical (an audible "click" will be heard when the conehead is fully engaged.) The bag is now mounted and ready for use.

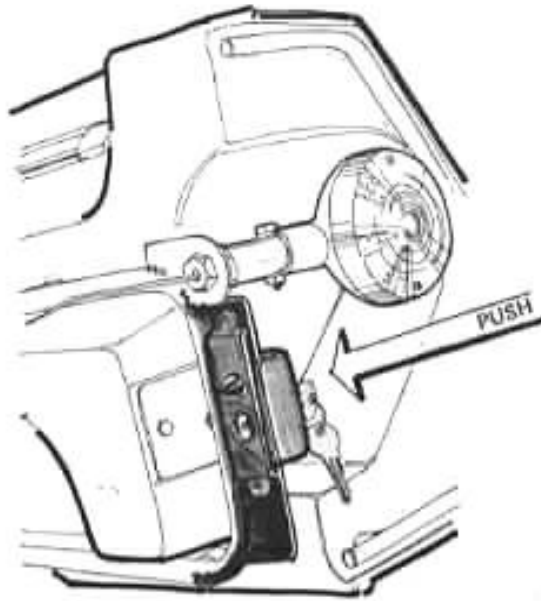

# 3

### Saddle bag removal

To remove the bag, simply turn the locking key to its release position, and pull the rear of the bag out and back to disengage the forward mount.

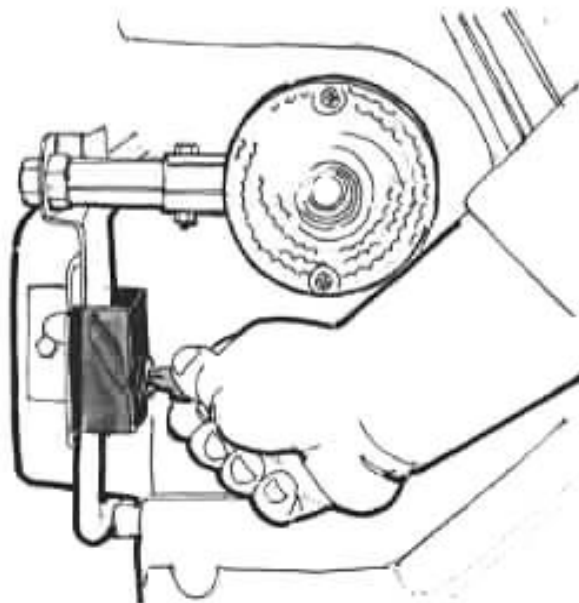



# 4

### Carrying the Floating Mount Saddle Bags by hand

When carrying the saddle bags by hand, they are designed to be carried with the doors facing you.

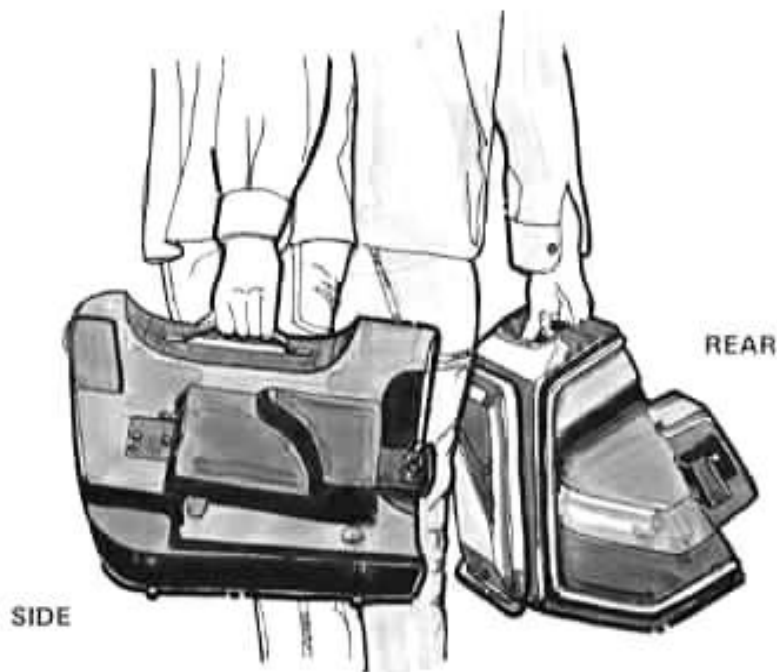

## **! WARNING**

**READ CAREFULLY  
BEFORE LOADING**



SADDLEBAGS, TAIL TRUNKS, AND LUGGAGE RACKS ARE PRIMARILY FOR LIGHT WEIGHT ITEMS. EXCESSIVE WEIGHT AND IMPROPER LOADING MAY AFFECT MOTORCYCLE STABILITY. DECREASE SAFE OPERATING SPEED, AND CAUSE MOUNTING HARDWARE FAILURE.



DO NOT EXCEED A MAXIMUM LOAD OF 25 KG (60LBS) TOTAL IN THE SADDLEBAGS AND TAIL TRUNK OR RACK COMBINED. DISTRIBUTE THE LOAD EQUALLY ON BOTH SIDES OF THE MOTORCYCLE.



FACTORS BEYOND OUR CONTROL SUCH AS OPERATOR'S WEIGHT, PASSENGER'S WEIGHT, WEIGHT OF OTHER ACCESSORIES, ETC. MAY FURTHER REDUCE THE SAFE AMOUNT OF WEIGHT CARRIED IN OUR BAGS AND TRUNK.



DO NOT EXCEED *YOUR* MOTORCYCLE'S VEHICLE CAPACITY LOAD LIMIT AS SHOWN ON ITS TIRE INFORMATION LABEL AND AGAIN IN YOUR MOTORCYCLE OWNERS MANUAL.



REFER TO THE INSTALLATION INSTRUCTIONS FOR ADDITIONAL INFORMATION. IF YOU HAVE ANY QUESTIONS, CONTACT YOUR DEALER, OR:

CUSTOMER SERVICE DEPT.  
VETTER FAIRING COMPANY  
RANTOUL, IL. 61866  
217-893-8300

## ELECTRICAL

If your problem is electrical, check your color code to insure the proper wires have been connected. A loose bullet connector connection can be improved by unplugging the connector and making the female receptacle smaller by use of pliers and then reinstalling the bullet connector. If your turnsignals do not function properly, your ground connection is probably not making good contact, or your battery is weak and needs to be serviced.

If there are any problems that cannot be solved by you or your dealer, contact the Customer Service Department of Vetter Fairing Company, Rantoul, Illinois 61866. Phone (217) 893-0300.

## MOUNTING

The best answer to almost any problem is to reread your instructions carefully. Sometimes it is helpful for someone else to look the problem over, especially someone who has not been working on the installation with you.

## MAINTENANCE

The Floating Mount Saddle Bags require little maintenance, but we recommend that you make periodic checks. The mounting bolts and mounting clamps should be checked for tightness and adjustments made as necessary.

Cleaning and waxing the Saddle Bags: When washing your saddle bags, use a mild detergent and warm water. Washing should be done with a soft cloth or sponge. Waxing the saddle bags is easy; furniture polish works as well as anything we have found.

**CAUTION:** Do not use cleansers which contain methyl or ethyl alcohol.

**CAUTION:** Hydraulic fluid will damage your Saddle Bags. Never allow it to come in contact with your saddle bags.

## PAINTING INSTRUCTIONS

If you wish to repaint your saddle bag doors, we recommend that the following instructions be used:

1. Remove the Floating Mount logo and stripe decals.
2. Sand thoroughly with 320 grit wet sandpaper.
3. Resand with 400 grit wet sandpaper.
4. Dry thoroughly.
5. Spray with DuPont 1005 Multi-Purpose Primer.
6. Spray DuPont Weight Lifter Acrylic Enamel with 7925 Hardener.
7. Reinstall vinyl decals.

## SADDLE BAG STRIPING

When removing striping from the saddle bag doors, the suggested method is to use 3M Woodgrain and striping Remover, part number 88907, followed by 3M Adhesive Remover, part number 88908. Please follow the directions on the spray cans. These products can be obtained at most paint and automotive stores that carry 3M products.

When handling saddle bag striping, do not crease or bend it. Always handle striping from the edges, never from the ends. Do not pull the backing paper off the striping with expectations of reapplying. Backing paper will NOT restick.

If you have any questions on storing, handling, removing or applying of saddle bag striping that your dealer cannot answer, contact our Customer Service Department.

## REPLACEMENT PARTS

We recommend that you always use Genuine Vetter Replacement Parts. Contact your local Vetter dealer to purchase or order replacement parts.

## CUSTOMER SERVICE

Any problems concerning installation of the Saddle Bags should be referred to your dealer or the Customer Service Department, Vetter Fairing Company, Rantoul, Ill. 61866. We are here to serve you-217/893-0300. In order to provide the maximum amount of service to you and the dealer, it is necessary that you fill out the Owner's Registration Card and promptly return it to Vetter Fairing Company. We also suggest you record your saddle bag serial number here \_\_\_\_\_

so you'll have it should you ever need to contact us.

This Warranty applies to products manufactured or distributed by Vetter Fairing Company, Rantoul, Illinois, 61866, and sold by Vetter Fairing Company or its authorized dealers within the United States, Puerto Rico, and the Virgin Islands. It is given to the first retail purchaser only and is not transferable to subsequent owners.

**Warranty Obligation:** Vetter Fairing Company warrants that it, or one of its authorized dealers, will repair or, at its option, replace any part proven to be defective in factory material or workmanship within six (6) months (unlimited mileage) of the date of purchase. Parts repaired or replaced under this warranty are warranted only during the balance of the original warranty period. **THIS WARRANTY DOES NOT INCLUDE ANY LABOR CHARGES FOR TROUBLESHOOTING, REMOVAL OR INSTALLATION.**

**Exclusions from Coverage:** 1. Any repairs or replacements or parts necessitated by misuse, negligence, fire, accident, damage caused by exposure to gasoline, brake fluid, harmful solvents and cleaners, paints, or repair material, use of unauthorized accessories, faulty installation, installation upon motorcycles or vehicles not listed in Vetter Fairing Company's retail and dealer catalog sheets, or improper or unreasonable maintenance are not covered. 2. This warranty does not cover "Totes" rainboots.

**DISCLAIMER OF CONSEQUENTIAL DAMAGES AND LIMITATIONS OF IMPLIED WARRANTIES: TO THE EXTENT THE LAW PERMITS, VETTER FAIRING COMPANY SHALL NOT BE LIABLE UNDER ANY CIRCUMSTANCES FOR LOSS OF USE OF THE PRODUCT, CONSEQUENTIAL OR INCIDENTAL DAMAGES, ANY IMPLIED WAR-**

**RANTY ARISING UNDER LAW, INCLUDING THOSE OF MERCHANTABILITY AND FITNESS FOR A PARTICULAR PURPOSE, IS LIMITED TO THE DURATION OF THIS LIMITED WARRANTY.**

**IMPORTANT:** Some states do not allow limitations on how long an implied warranty lasts and/or limitations or exclusions or consequential or incidental damages, so the above limitations may not apply to you.

**To Obtain Warranty Service:** Information you must provide when filing claim: 1. Name, mailing address and telephone number. 2. Selling dealer's name and address. 3. Serial number of the product. 4. Model and year of motorcycle. 5. Date product was purchased. 6. Date and mileage at failure. 7. Description of problem.

**Steps to take:** 1. Contact or take your product to an authorized Vetter dealer (preferably your selling dealer) at your expense. 2. If you are unable to obtain warranty service, or should your warranty claim be denied for reasons that you consider unjustifiable, contact the owner of your selling dealer. Normally, this should resolve your problem. However, if you require further assistance, write or call the Customer Service Department of Vetter Fairing Company, Rantoul, Illinois, 61866; Phone: (217) 893-0300. At this point, you must be prepared to return the part in question to Vetter Fairing Company with all freight charges prepaid. The charges will be reimbursed to you if they total over \$5.00 (five dollars) and the warranty claim is honored. This warranty gives you specific legal rights and you may also have other rights which vary from state to state.

January 1, 1977

Vetter Fairing Company, Inc.

## TROUBLESHOOTING AND MAINTENANCE

## LIMITED WARRANTY VETTER FAIRING COMPANY PRODUCTS

