

WARNING

THIS BRACKETING AND THESE INSTRUCTIONS WERE DESIGNED SOLELY FOR USE IN MOUNTING THE VETTER QUICKSILVER FAIRING TO THIS SPECIFIC MOTORCYCLE. IF YOU ARE UNABLE TO DETERMINE IF THIS HARDWARE IS FOR YOUR MOTORCYCLE, CONTACT YOUR DEALER. IF YOUR DEALER IS UNAVAILABLE, CONTACT THE CUSTOMER SERVICE DEPARTMENT, VETTER CORPORATION, RANTOUL, IL 61866 (217) 893-9300. THESE INSTRUCTIONS CONTAIN VALUABLE INFORMATION FOR FUTURE REFERENCE. THEY MUST BE GIVEN TO THE CUSTOMER.

Table of Contents

Prepare the Motorcycle . . . 3
Install Mounting Bracket . . 7
Electrical Connection. . . .10
Fairing Mounting11

These instructions explain the procedure required to mount the Quicksilver fairing to your motorcycle. We urge you to follow the preparation and assembly sequence from start to finish.

Prepare the Motorcycle

CB550K Only

1. Put the motorcycle on its centerstand.
2. Turn the fuel petcock to the off position. Disconnect the fuel line. Remove the gas tank.
3. Remove the three phillips screws. Unplug and remove the headlight.
4. Disconnect all wiring block connectors. Disconnect the turnsignal wires: Right-light blue/light blue-white; Left-orange/orange-white; Ground-green.
5. Remove the side reflectors from the nacelle. Remove the nacelle feeding the wires carefully through the rear of the nacelle.
6. Disconnect the tachometer and speedometer cables.
7. Remove the side pinch bolts of the triple clamp letting the beeper on the left side dangle. Loosen the center pinch bolt. Remove the large cap nut. Carefully lift the triple clamp. (Illus. a)
8. Remove the headlight stays/turnsignal assemblies, and rubber grommets.

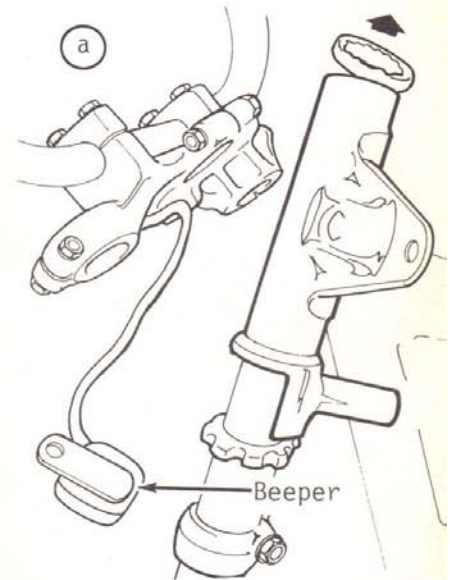

9. Reinstall the triple clamp/handlebar assembly, tightening the large cap nut. Relocate the beeper on the right side of the triple clamp (Illus. b). Tighten pinch bolts (Illus. c).
10. Disconnect the horn wires and remove the horn.

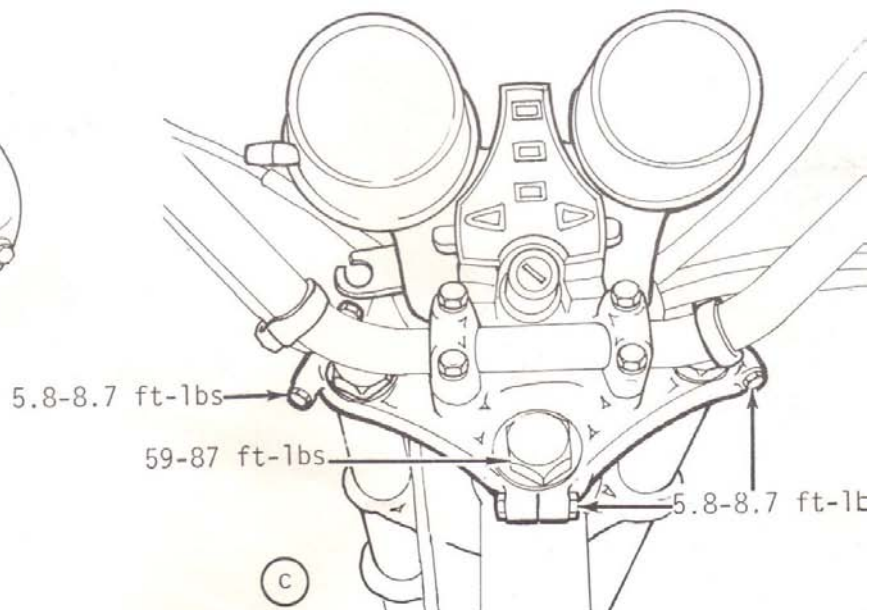
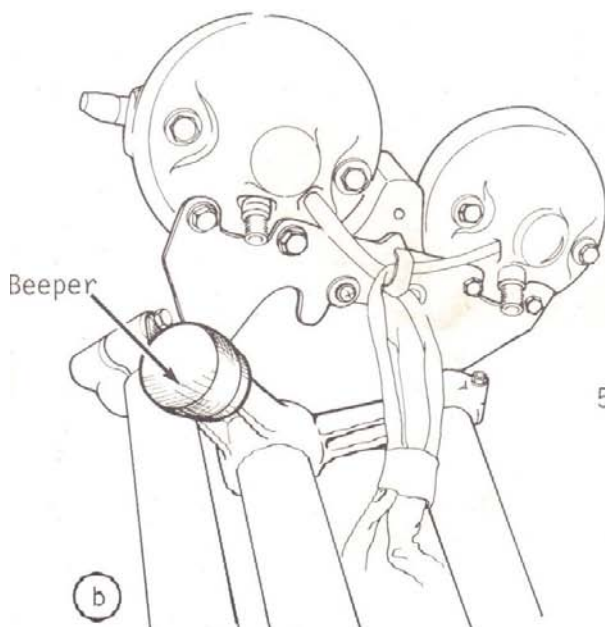

1. Put the motorcycle on its centerstand.
2. Remove the rear gas tank mounting bolt. Disconnect the fuel line. Remove the gas tank.
3. Remove the two phillips screws from the nacelle. Unplug and remove the headlight.
4. Disconnect the turnsignal wires: Right-Light Blue/Light Blue-White; Left-Orange/Orange-White; Ground Green. Disconnect all the wires and block connectors.
5. Remove the turnsignal and mounting bracket from the lower triple clamp. Reinstall the lower triple clamp pinch bolt (Illus.d).

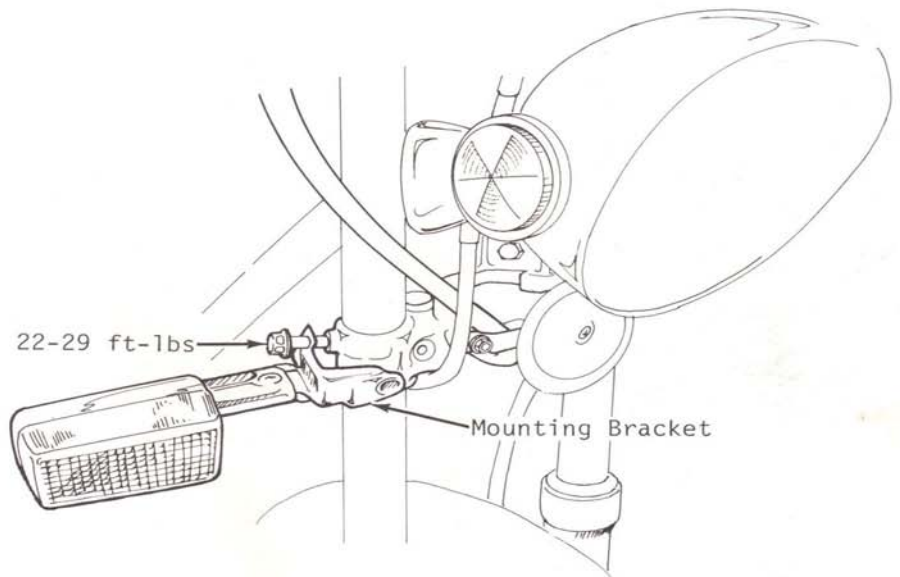
**d****5**

6. Remove the side reflectors on the sides of the nacelle. Remove the nacelle, carefully feeding the wires through the hole at the rear.
7. Disconnect the tachometer and speedometer cables.
8. Disconnect the flasher unit from the headlight stay bracket (Illus. e)
9. Disconnect the horn and remove it from the stay bracket.
10. Remove the 10mm nuts from the instrument panel bracket. Lift the panel to free the headlight stay assembly and carefully remove the stay (Illus.e).

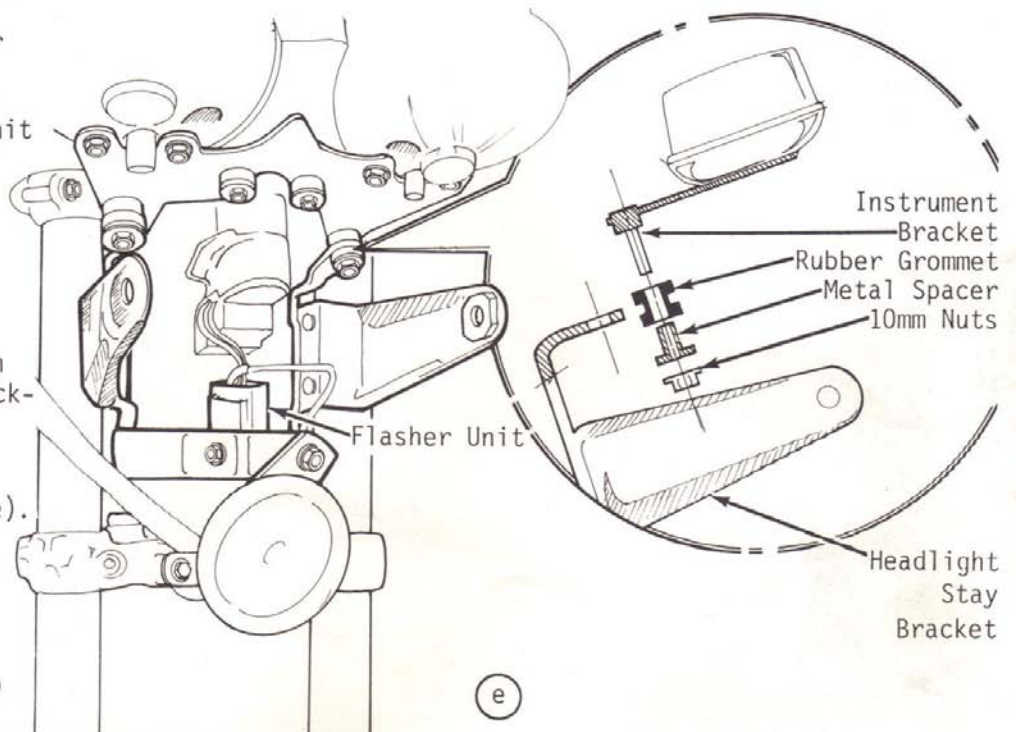
**e**

11. Remove the metal spacers and the rubber grommets from the headlight stay assembly. Reinstall them in the upper triple clamp as shown (Illus. e).

Install Mounting Bracket

CB550K Only

Position the mounting bracket on the frame tubes feeding the tachometer cable between the crosstubes (Illus. f).

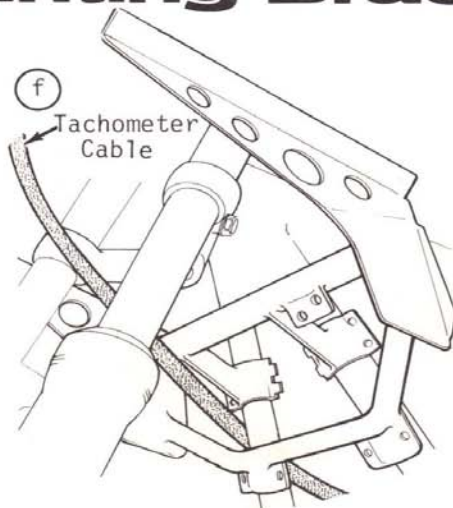

CB650 Only

Position the bracket on the frame tubes routing the clutch cable below the mounting bracket, in front of the crosstubes. The tachometer cable must be routed above the crosstubes and underneath the lower triple clamp (Illus. g).

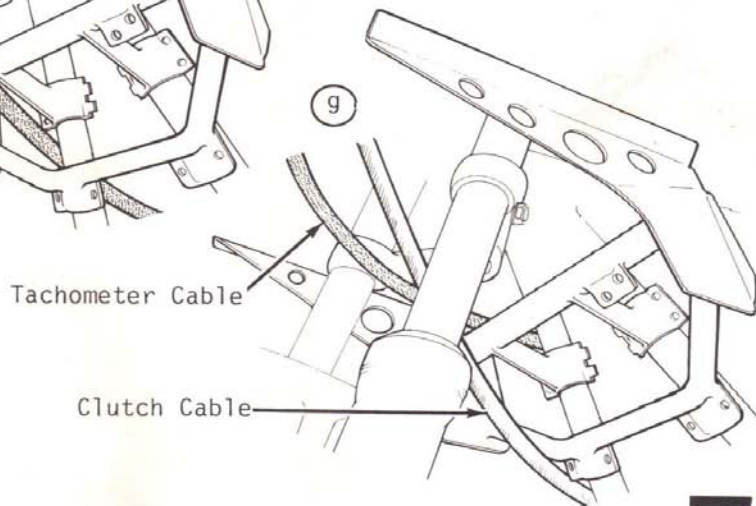

7

2. Install the ses clamp buckles using the provided 6x25mm bolts and flat washers as shown. (Illus. h) Do not tighten completely.
3. Install the provided U-bolts, flat washers, and locknuts as shown. Do not tighten completely. (Illus. h)

WARNING

BEFORE TIGHTENING THE SES CLAMPS, CHECK THE FULL LOCK POSITION OF THE HANDLEBARS. THERE MUST BE CLEARANCE BETWEEN THE UPPER CROSSTUBE AND THE LOWER TRIPLE CLAMP IN THIS POSITION.

4. View the bracket from directly in front of the motorcycle. If the bracket is not level, tap it into position as required (Illus. i).

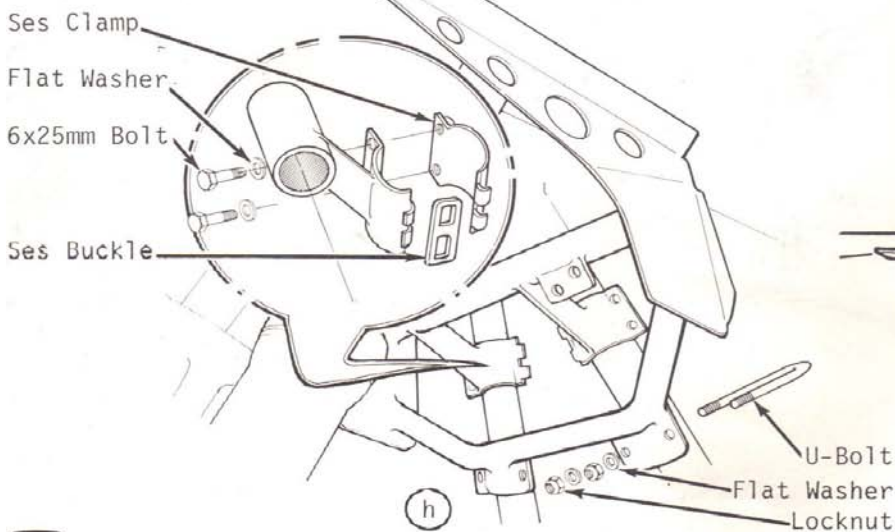

8

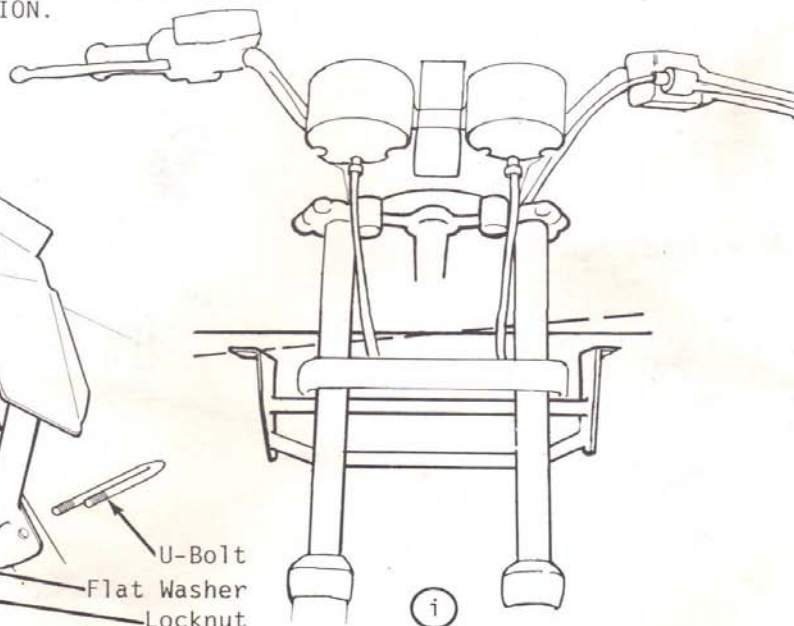

- Tighten bolts and locknuts. Do not over tighten.
- Reconnect the tachometer and speedometer cables.

CB550K Only

Relocate the horn on the tab on the mounting bracket with the supplied 6x20mm bolts, flat washers, and locknuts. Tighten bolts. Do not over tighten (Illus. j). Reconnect the horn wires.

CB650 Only

Relocate the horn on the right mounting bolt of the brake hose guide stay. (Illus. k)

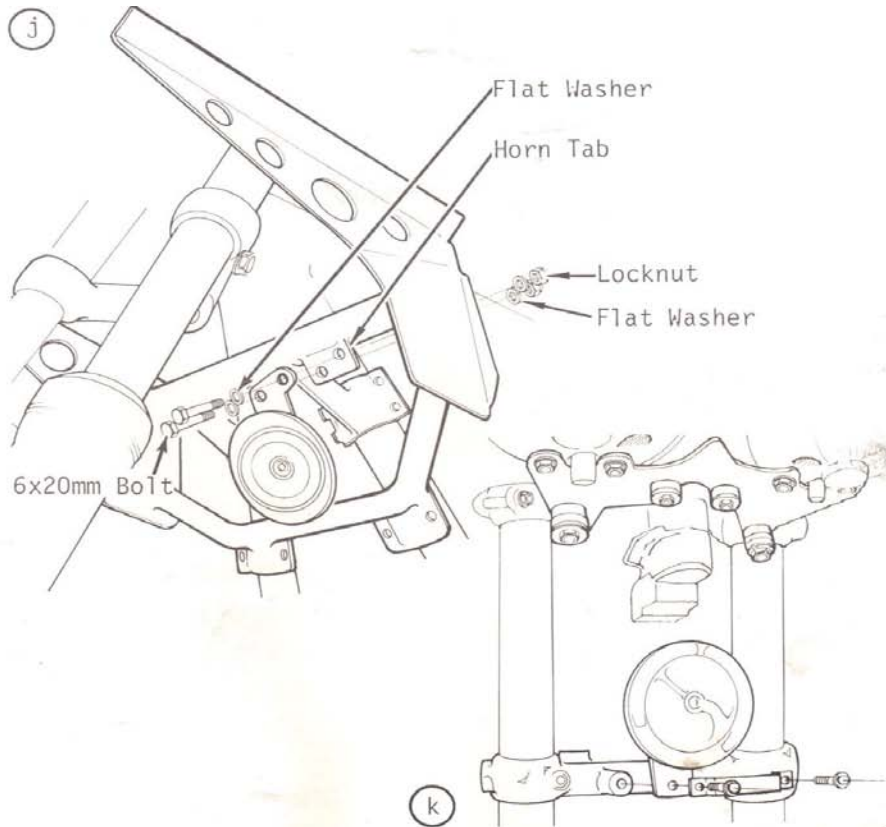

9

Electrical Connections

- Temporarily hang the fairing on the mounting bracket as shown. (Illus. l)
- Refit all the wiring block connectors to their original counterparts.
- Route the Vetter wiring harness between the frame and left fork tube as seen from the seat. (Illus. l) Attach the 3-prong plug in the harness to the motorcycle's headlight socket.
- Connect the remaining wires following the color code:
- Cover all the wiring connectors with the black vinyl bag supplied. Cinch up the drawstring and position the bag upside-down to keep water out. Secure the long cable tie around the bag and the tachometer cable. (Illus. m)

3. Route the Vetter wiring harness between the frame and left fork tube as seen from the seat. (Illus. l) Attach the 3-prong plug in the harness to the motorcycle's headlight socket.

- Connect the remaining wires following the color code:

Fairing	Function	Bike
Violet	.Left Turnsignal	. Orange
Blue	.Right Turnsignal.	. Light Blue
Green.	.Running Lights.	. Brown

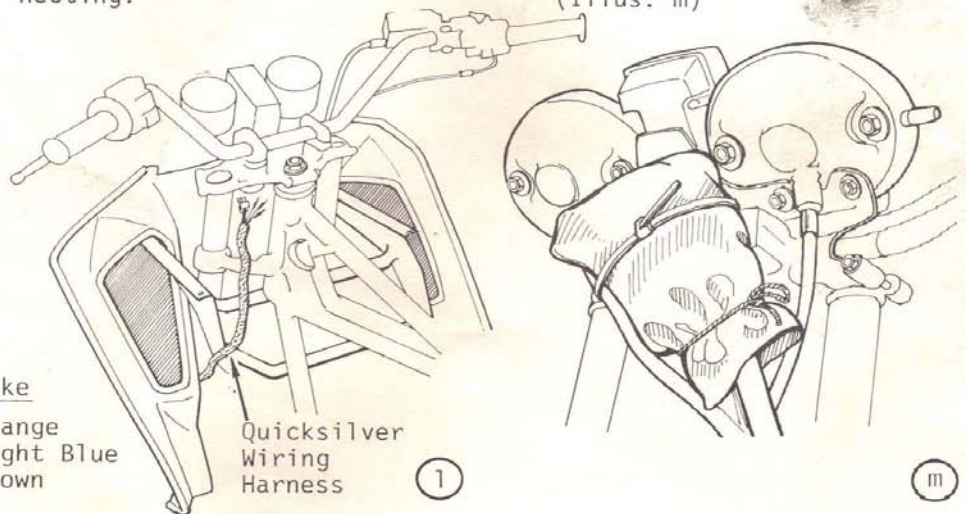

10

Fairing Mounting

1. Peel the protective paper backing off the neoprene mounting pads, being careful not to remove the yellow adhesive strips at the same time. Carefully line the pads up on the mounting rails making sure that the holes in the pad align with the holes in the rails.
2. Prepare two of the four 6x25mm bolts with provided Aztec washers. (Illus. n)
3. Set the fairing on the mounting rails and secure it at the rear mounting holes using prepared bolts. Tighten only until the fairing rests securely. Forward mounting will take place after the turnsignal installation.
4. Thread the supplied reflectors into the holes provided to the side plates as shown. (Illus. o)
5. Secure the tank, and connect the fuel line.

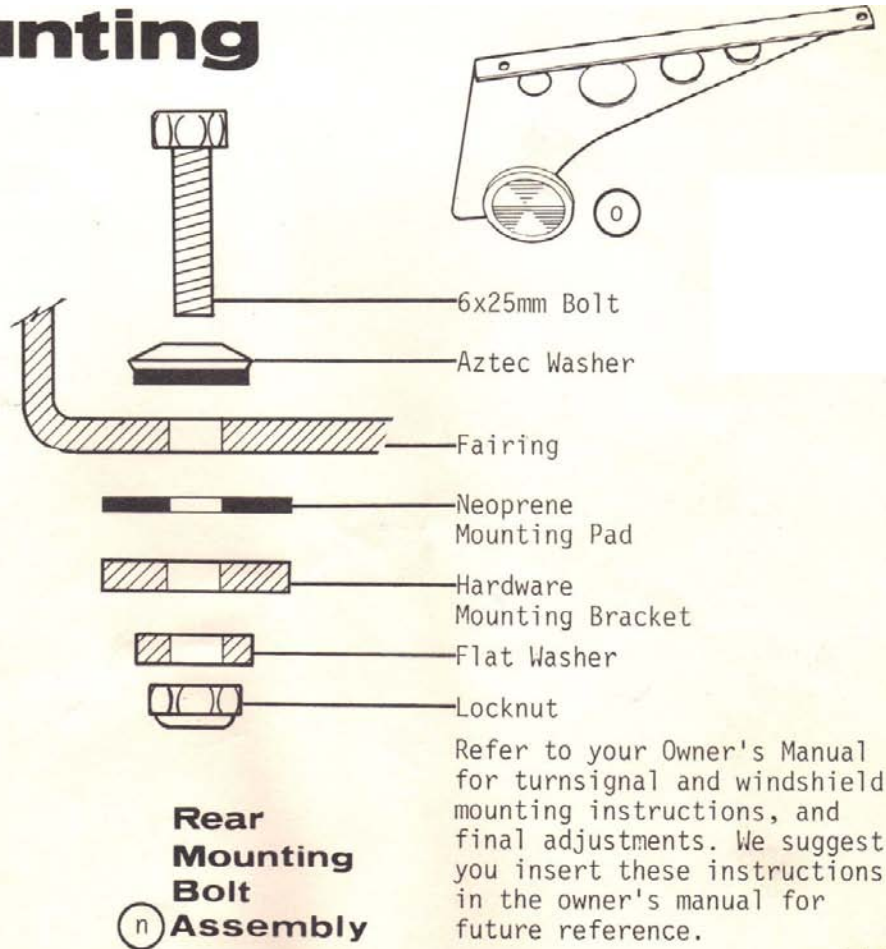

11

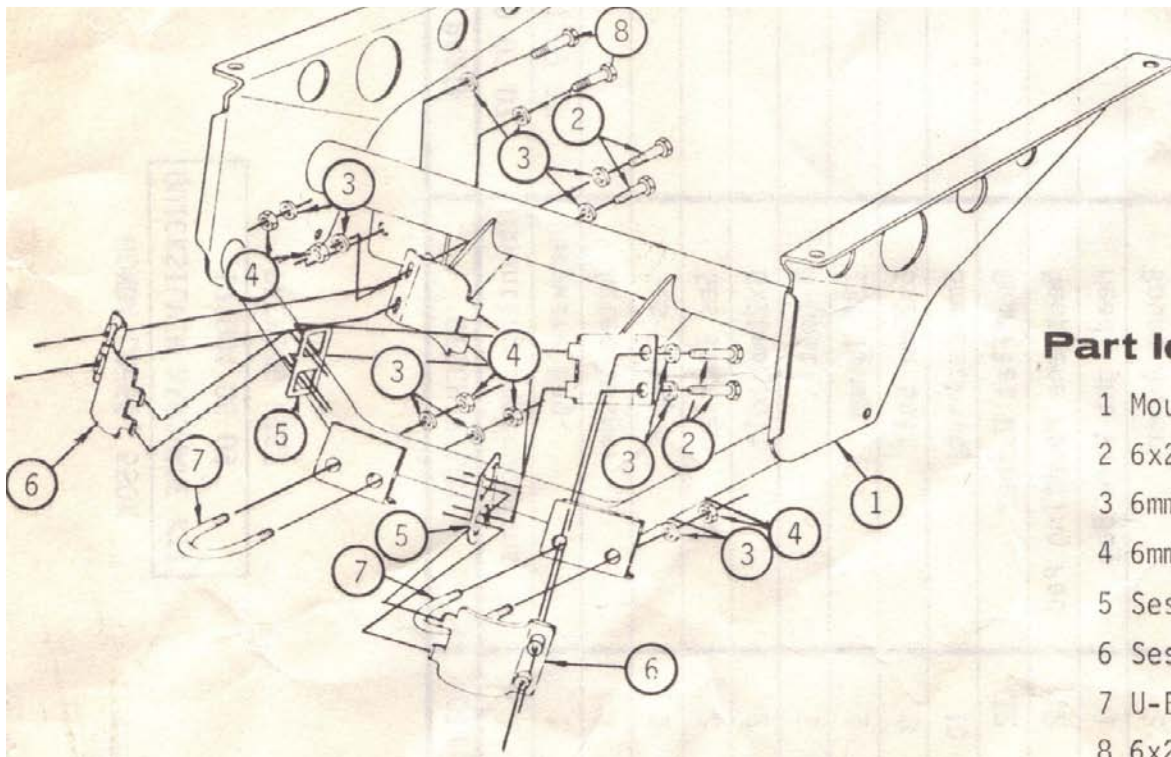

Part Identification

- 1 Mounting Bracket
- 2 6x25mm Bolt
- 3 6mm Flat Washer
- 4 6mm Locknut
- 5 Ses Buckle
- 6 Ses Clamp
- 7 U-Bolt
- 8 6x20mm Bolt

14 011 07 04
©Vetter Corp. 1979
10-16-79

HONDA CB650, 550K

QUICKSILVER HARDWARE KIT

10 004 08 09

PACKING LIST

PART#	DESCRIPTION	QTY
14 010 07 07	Mounting Instructions	1
15 001 07 09	Hardware Bag	1
	Aztec Washer	4
	Ses Clamp	2
	Ses Buckle	2
	6x20mm Bolt	2
	U-Bolt	1
	13" Tyrap	1
	6x25mm Bolt	8
	6mm Locknut	10
	6mm Flat Washer	12
	Neoprene Mounting Pad	2
	Headlight Wire Bag	1
	Round Amber	2
15 016 01 07	Mounting Bracket	1

CAUTION

USE OF THE NEOPRENE MOUNTING PADS ON THE HARDWARE RAILS
HAS BEEN DISCONTINUED. PLEASE DISREGARD ANY REFERENCE
TO THEIR USE.