

Special Supplementary Instructions

December 27, 1973

SPECIAL ELECTRICAL COLOR CODE

Moto Guzzi 750
& 850

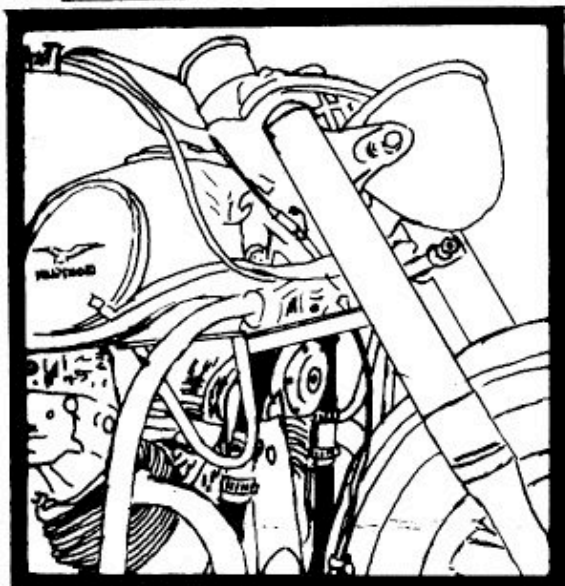

<u>Fairing Wire</u>	<u>Function</u>	<u>Bike Wire</u>
White.....	high beam.....	Black/Green
Yellow.....	low beam.....	Green
Black.....	ground.....	Black (located between terminal plates)
Red.....	left turnsignal...	Left labeled wire (route into headlight nacelle)
Blue.....	right turnsignal...	Right labeled wire (route into headlight nacelle)
Green.....	running lights.....	Black (3rd terminal on right side, when sitting on seat)

VFCo
Part #

Description

Quantity

0471	Moto Guzzi Mounting Kit Complete	1
0485	Moto Guzzi Mounting Bracket	1
0624	Moto Guzzi Hardware Bag	1

A. The Electrical System

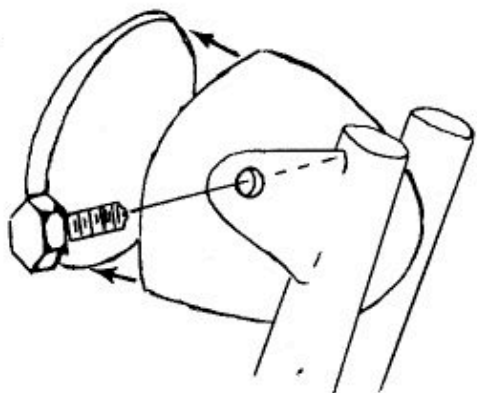

- 1a. Remove the motorcycle headlamp from the headlight nacelle.
- 1b. Remove the headlight nacelle mounting bolts.

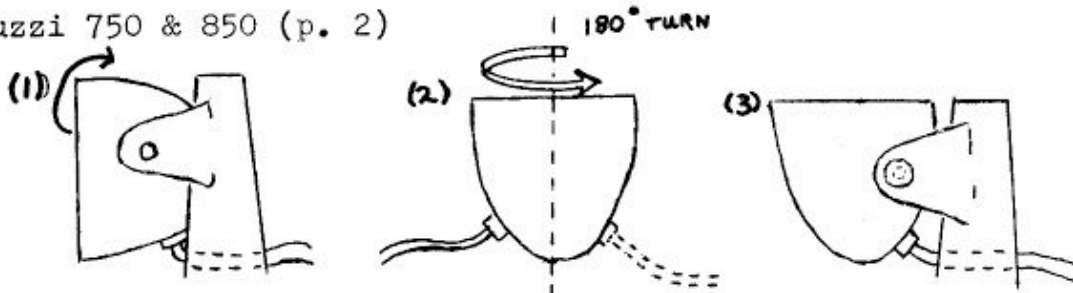

1c. Turn the headlight nacelle so that the bulb opening faces upward(1). Remove the nacelle and rotate it 180 degrees(2). Then replace the nacelle in this position so that the wires protrude at rear of nacelle(3).

d. Rebolt the headlight nacelle in this vertical position. This provides necessary clearance between the headlight nacelle and the fairing inner walls and, also, provides easy access to the fuses.

2. For bikes with turnsignals:

- a. Label the turnsignal wires "right" and "left" since they are not color coded.
- b. Cut the turnsignal leads 3" back from the bulb unit.



c. Route the turnsignal wires into the back of the headlight nacelle.

3a. Remove the turnsignal straps from the fork down tubes.

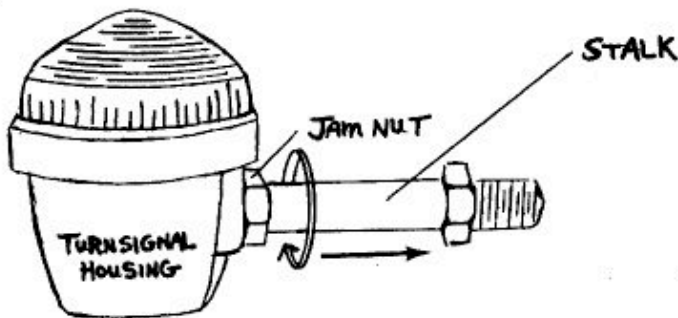

b. Loosen the turn-signal stalk on the turnsignal housing by backing the thread out as far as is practical and tighten the jam-nut.

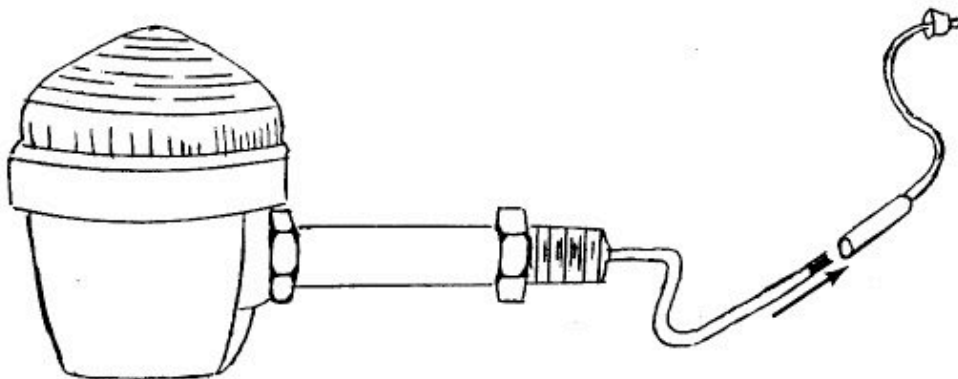

c. Extend the wire on the bulb units.

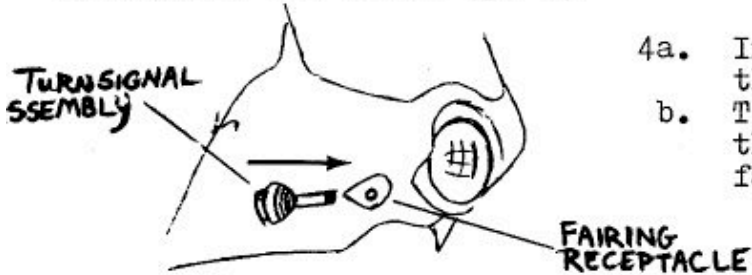

- 4a. Insert turnsignal assemblies into the fairing receptacles.
- b. Tighten the turnsignal units with the bulb unit as far away from the fairing as possible.

B. The Mounting Bracket Installation

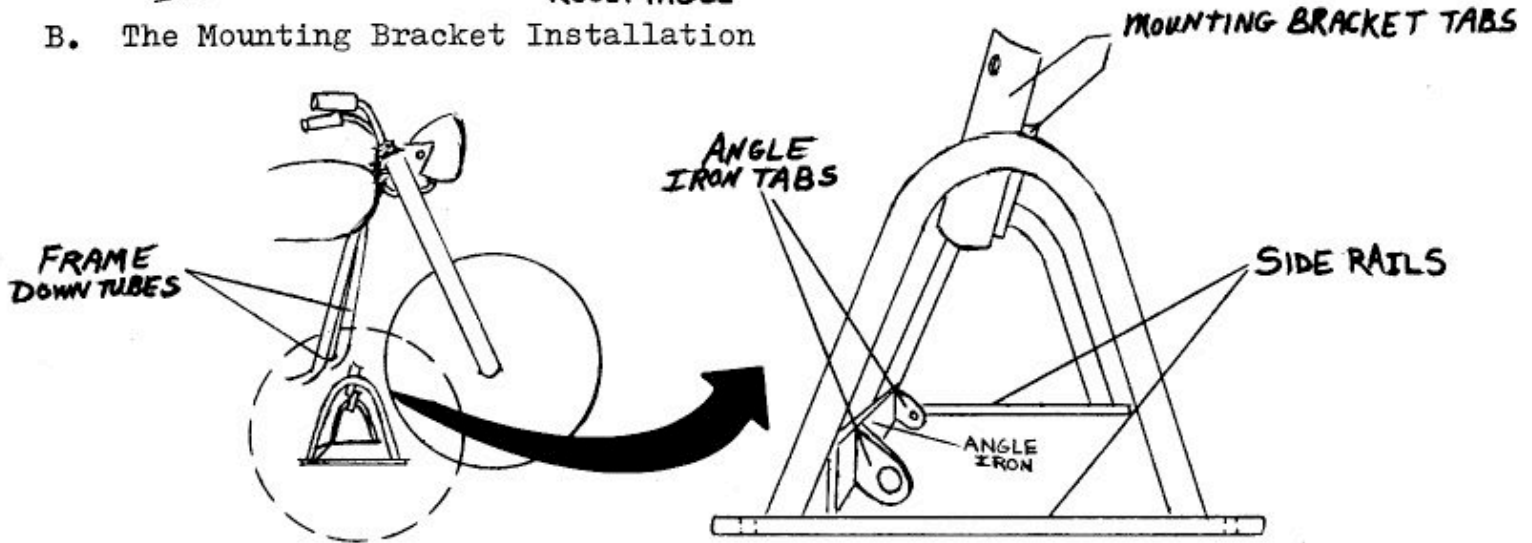

- 1a. Start with the mount placed on the floor upside down (the side rails resting on the floor with the angle iron crossmember towards the rear of the bike).

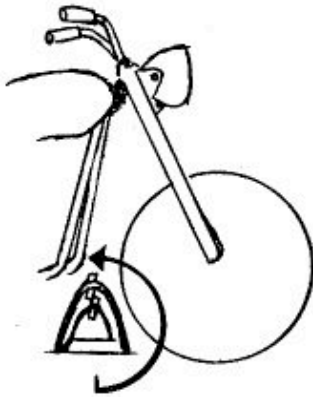

- b. The mount is now carefully raised between the fender and the engine. Simultaneously, turn the bracket 180 degrees before it is raised to position beneath the crash bar.

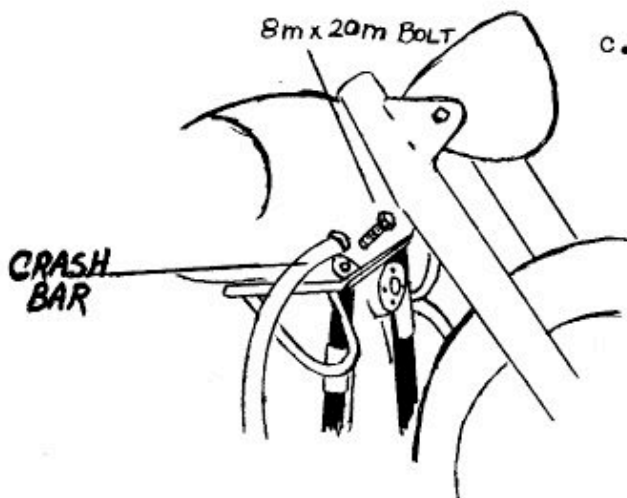

- c. Use the 8mm x 20mm bolts provided to loosely bolt the two angle iron tabs onto the upper crash bar mount.

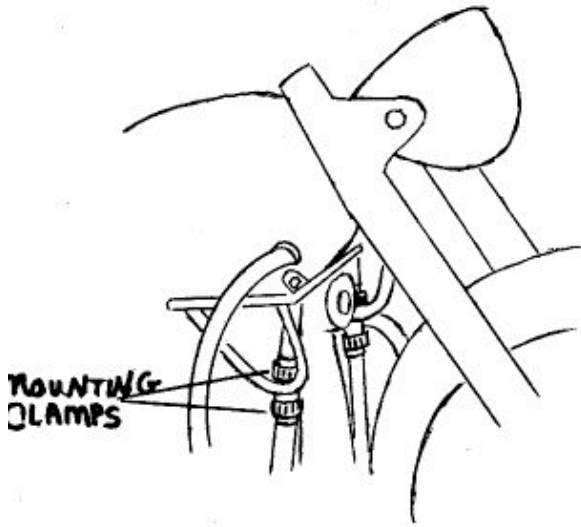

- 2a. Place the mounting clamps in position on the mounting bracket tabs and secure loosely.
- 3d. After checking for proper alignment, go back and tighten the mounting clamps and bolts securely.

- e. Loop the nylon cable tie around the handlebar and the throttle cable. Cinch it up only tight enough to prevent the cable from rubbing on the top of the fairing.