

---

# Windjammer SS/IV/V/Windstar Mounting Instructions

## HONDA 1981-82 CB900F

---

### *warning*

THE HARDWARE DESCRIBED IN THIS MANUAL WAS DESIGNED TO MOUNT THIS VETTER FAIRING TO THE MOTORCYCLE(S) DESIGNATED.

---

If you are unable to determine if this hardware is for your motorcycle, contact your dealer. If your dealer is unavailable, contact the Vetter Corporation Customer Service Department, Rantoul, Illinois 61866, (217) 893-9300. These instructions must be given to the customer.

### *note:*

This manual may cover several motorcycles and some illustration details may differ from your model, please follow the instructions.

---

## Prepare for Fairing Installation

---

1. Put the motorcycle on its center stand. Remove the two phillips head screws in the headlight rim; remove the rim and pull the headlight forward. Disconnect the 3-prong plug and remove the headlight.
  2. Disconnect the turnsignal wires on each side: Left-Orange, Orange/White, Green; Right-Blue, Blue/White.
  3. Disconnect the speedometer cables. Unplug all the wiring block connectors. Remove the headlight shell from the stays and pull the wiring harness back through the access holes. Remove the nacelle. It will not be reused.
  4. Remove the motorcycle gas tank to prevent damage during installation and to facilitate assembly.
-

13. Temporarily bolt the handlebars into place. Loosen the choke control and push it out of its guide to ease triple clamp removal.

14. Loosen the upper triple clamp pinch bolts. Lift the triple clamp/handlebar assembly up and to one side. Pull the turn-signal brackets off along with both rubber grommets. Repeat for the other side. (Illus. 5)

15. Reinstall the triple clamp.

16. Remove the handlebars from the triple clamp and replace the chrome cap nut. Tighten to factory torque specifications.

17. Reinstall the air equalizer tube on the fork tops being careful not to damage the O-rings. (Illus. 3)

18. Remount the handlebars and tighten securely. Replace the choke control in its guide and tighten.

19. Tighten the two pinch bolts to factory torque specifications.

**note:** Refer to the CB-900 F Owner's Manual for proper procedure in air fork pressure adjustment.

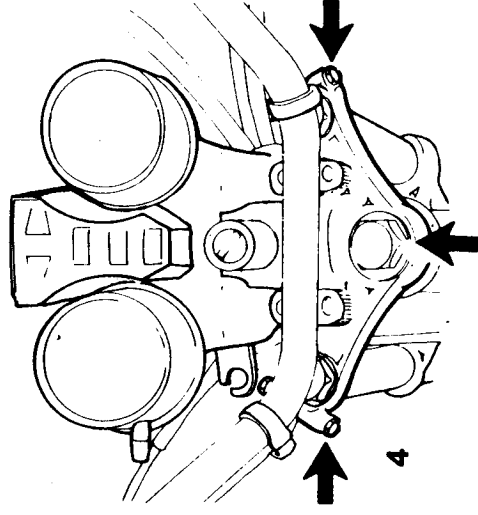

4

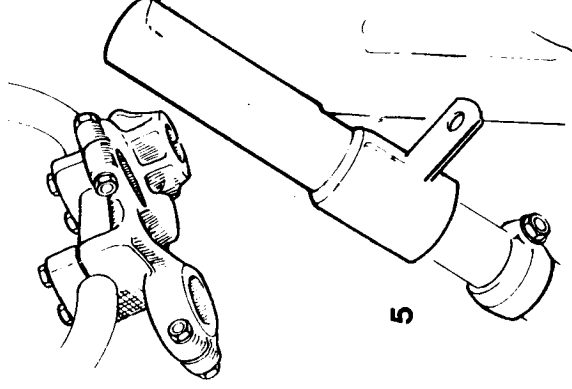

5

---

## Electrical Connections

---

1. Refit all the wiring block connectors to their original counterparts.
2. Route the Vetter wiring harness between the frame and left fork tube. Attach the 3-prong plug in the harness to the motorcycle's headlight socket.

## Install Mounting Bracket

**note:** For detailed information on the use of engine guards with this hardware, consult page 5 of your Fairing Owner's Manual.

### **warning**

**DUE TO THE DESIGN OF THIS PARTICULAR BRACKET, IT SHOULD NOT BE CUT OR ALTERED IN ANY MANNER TO ACCEPT ANY TYPE OF ENGINE GUARD.**

1. Remove the clip located on the bottom of the oil cooler tab.
2. Remove the two 6mm cap nuts which hold the oil cooler to the frame down tubes.
3. Lifting the oil cooler forward and up, remove it from the frame and let it hang to one side being careful not to damage any oil lines. Remove the two rubber isolators from the frame.

### **note:**

To provide proper clearance for the oil cooler, the lower mounting tab must be cut off flush with the frame. Failure to do so will result in damage to the oil cooler and engine. (Illus. 7)

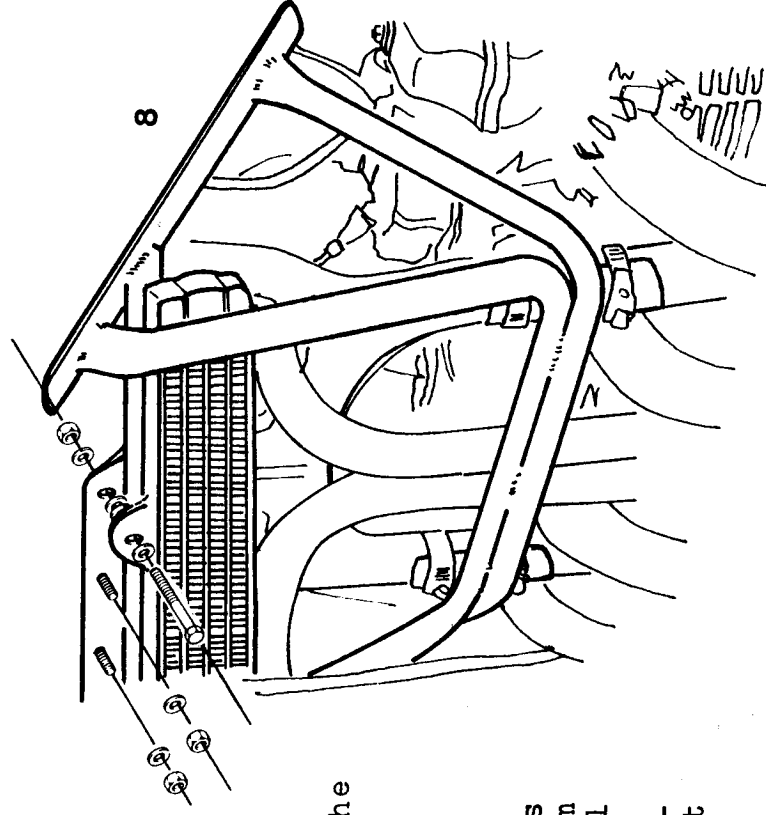
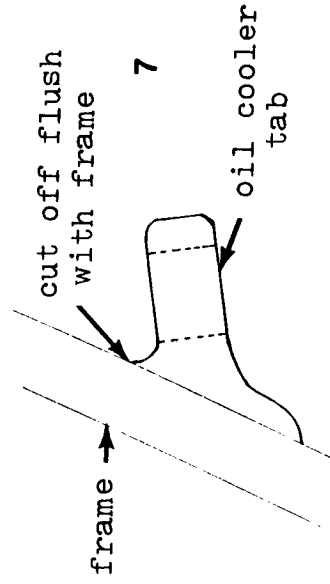

4. Install two hose clamps on the lower frame down tubes.
5. Install the bracket on the frame running the oil cooler through the center of the bracket so that the oil lines are located behind the bottom bracket cross tubes. Install the lower two hose clamps loosely on lower bracket saddle pads. (Illus. 8) Do not tighten.

1. Prepare four 6x35mm bolts with flat washers and neoprene washers as shown. Insert the bolts in the mounting holes in the fairing.
2. Set the fairing on the mounting bracket so the four bolts drop through the holes. Install lock nuts on the bolts, but do not tighten completely. (Illus. 11)
3. Before tightening the nuts, plug the external wire harness into the fairing at the serial number plate. Check all electrical components before continuing. Refer to the Troubleshooting section in your Fairing Owner's Manual if problems arise.
4. Now tighten the four bolts enough to slightly compress the neoprene washers.
5. Fit the reflectors to the mounting clamps with the 6mm nuts provided.
6. Install each assembly on the fork slider as shown. (Illus. 12)

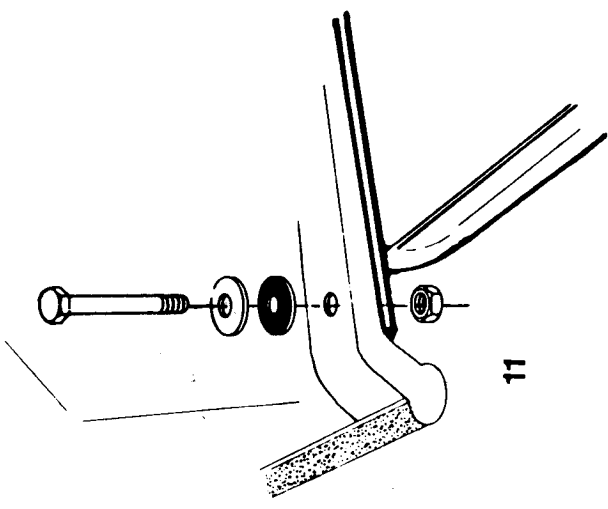

11



12

Refer to your Owner's Manual for windshield mounting instructions and final adjustments. We suggest you insert these instructions in the manual for future reference.

USE THIS SCALE TO CHECK BOLT AND WASHER DIMENSIONS

