

Windjammer SS/IV/V / Windstar Mounting Instructions

YAMAHA 1974-81 XS650; All Models 1982 XS650S

warning

THE HARDWARE DESCRIBED IN THIS MANUAL WAS DESIGNED TO MOUNT THIS VETTER FAIRING TO THE MOTORCYCLE(S) DESIGNATED.

If you are unable to determine if this hardware is for your motorcycle, contact your dealer. If your dealer is unavailable, contact the Vetter Corporation, Customer Service Department, Rantoul, IL 61866 (217) 893-9300. These instructions contain valuable information for future reference. They must be given to the customer.

note: This manual may cover several motorcycles and some illustration details may differ from your model. Please follow the instructions.

Prepare for Fairing Installation

1. Put the motorcycle on its center stand. Remove the seat and gas tank to prevent damage and facilitate assembly.
2. Remove the two phillips head screws in the nacelle and remove the headlight.
3. Disconnect all wiring block connectors inside the nacelle.
4. Remove the two 8mm bolts holding the nacelle to the headlight stays and the 6mm headlight adjustment bolt located at the bottom of the nacelle.
5. Remove the bolts holding the turnsignal assemblies and remove the turnsignals.

USE THIS SCALE TO CHECK BOLT AND WASHER DIMENSIONS

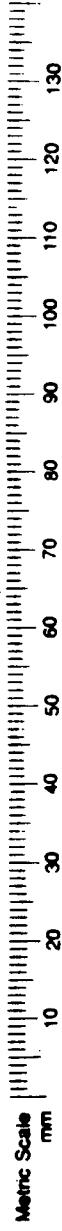

6. Remove the side reflectors.

1979-81 XS650 only:

- A. Disconnect and remove the horn and its mounting bracket from the stock mounting location. Retain all nuts, bolts, and hardware for remounting.
- B. Remove the rubber grommets and metal bushings from the stock horn bracket. Reinstall them on the supplied horn bracket as shown. (Illus. 1)

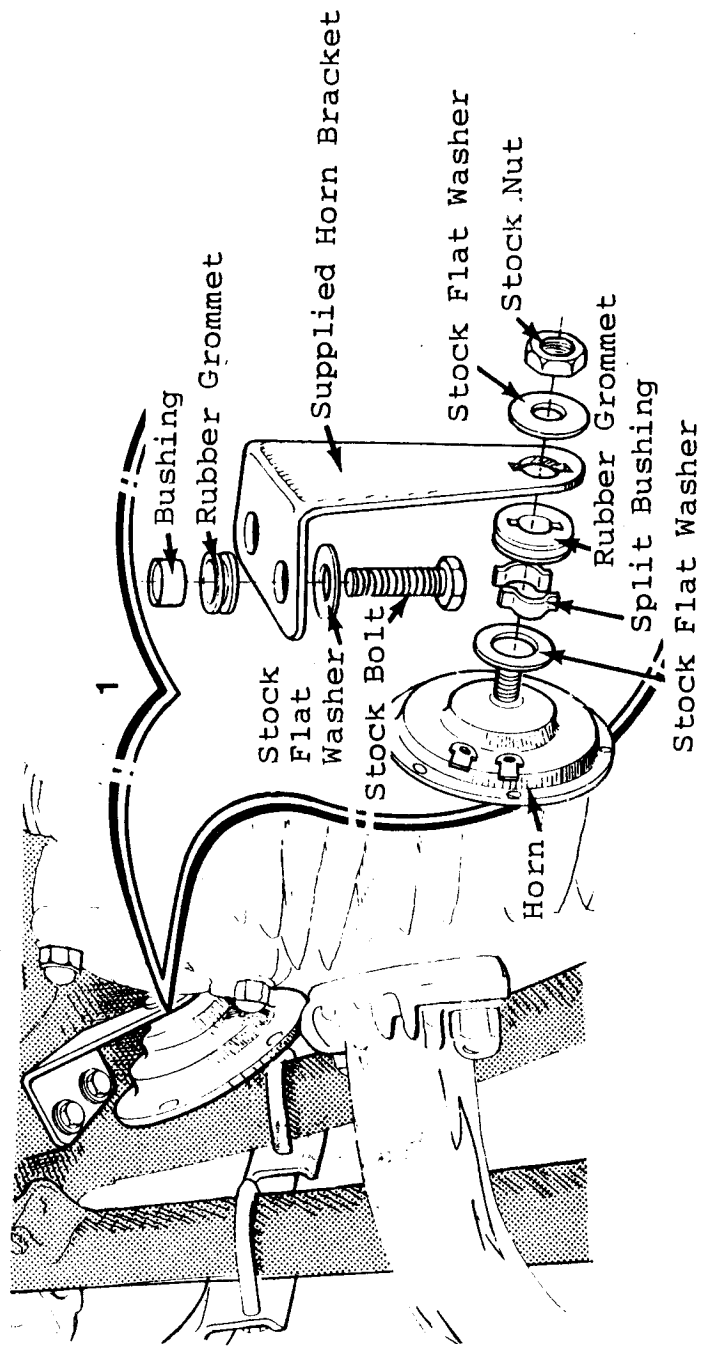

C. Position the bracket on the bike behind the frame gusset using the stock bolts and flat washers as shown.

D. Mount the horn on the bracket using the stock flat washers and stock nut as shown.

E. Reconnect the horn wires.

F. Disconnect the tachometer drive cable at the engine. Pull the cable up through the lower two guides and let hang for now.

Electrical Connections

1. Refit all the wiring that was disconnected to remove the nacelle.

2. Route the Vetter wiring harness between the frame and the left fork tube. Attach the 3-prong plug in the harness to the motorcycle's headlight socket.

3. Connect the remaining wires following the color code below:

Fairing Wire	Function	Bike Wire
White.....	High Beam.....	Yellow
Yellow.....	Low Beam.....	Green
Black.....	Ground.....	Black
Violet.....	Left Turnsignal.....	Brown
Blue.....	Right Turnsignal.....	Olive Green
Green.....	Running Lights.....	Blue
Red.....	Cigarette Lighter.....	Light Brown
Brown.....	Windjammer (horn opt).....	Battery Wire (+)
Orange.....	Windstar 12V Unswitched	
	Windjammer (horn opt).....	Pink
	Windstar 12V Switched.....	Light Brown

caution

THE ORANGE, BROWN AND RED FAIRING WIRES ARE CONNECTED AS ABOVE ONLY FOR THE ACCESSORIES LISTED. ANY WIRING NOT USED SHOULD BE COVERED AT THE END WITH ELECTRICAL TAPE. IF YOU DECIDE TO USE THESE WIRES FOR OTHER ACCESSORIES, MAKE SURE YOUR MOTORCYCLE'S ELECTRICAL SYSTEM WILL TOLERATE THE EXTRA CURRENT DEMAND.

Plug the male bullets into the appropriate female connectors. Gently pull all connectors to make sure they are tight. If not, crimp the outside of the connectors with wire crimpers or pliers after the connection is made. (Illus. 2)

For wires without connectors, use the provided blue connectors as shown.

- Snap the blue connector over the appropriate motorcycle wire.
- Insert the appropriate fairing wire into the other hole. The wire will not go all the way through the connector.
- Squeeze the metal tab down flush with the top of the connector.
- Fold the plastic lid down and snap it shut.

4. Cover all the wiring connections with the black vinyl bag supplied. Cinch up the drawstring and place the bag upside down to keep water out. Hook two ty-raps end to end and secure the bag to the wire harness going into the instrument panel.

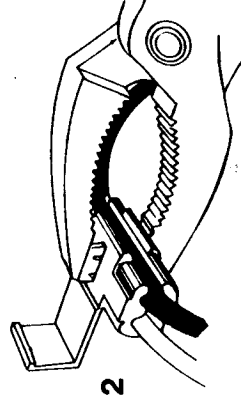

Install Mounting Bracket

note: For detailed information on the use of engine guards with this hardware, consult page 5 of the Owner's Manual.

warning

DUE TO THE DESIGN OF THIS PARTICULAR BRACKET, IT SHOULD NOT BE CUT OR ALTERED IN ANY MANNER TO ACCEPT ANY TYPE OF ENGINE GUARD.

1. Position the mounting bracket on the frame as shown and fit two mounting clamps to each pad. Do not tighten completely. (Illus. 3)
2. View the bracket from directly in front of the motorcycle. If the bracket isn't level, lightly tap it into position as required.
3. Tighten all mounting clamps securely.
4. Reroute the tachometer drive cable but do NOT use the center cable guide on the frame. Instead, run the cable in front of the bracket and through the lower cable guide. Connect the cable back to the original position.

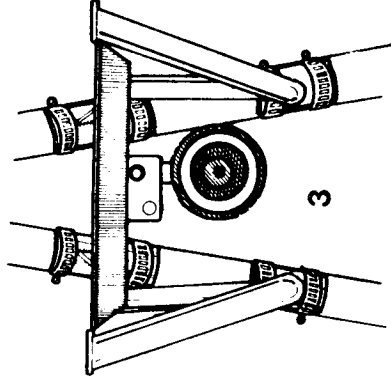

warning

FOR YOUR OWN PROTECTION, USE ALL PROVIDED MOUNTING CLAMPS AND CHECK THEM PERIODICALLY FOR TIGHTNESS.

Mount the Fairing

WJ SS/IV only:

If you are planning to install Vetter color inserts, they should be applied before the fairing is mounted.

note:

If you are installing the optional horns, refer to the instructions packaged with the horn kit.

1. Place one of the supplied rubber bushing in each of the large holes on the mounting bracket.
2. Place a 1 1/4" fender washer on the top of each bushing.

- Place one of the supplied rails on each fender washer on each side of the mounting bracket.

note:

The rails should be positioned with the pointed end in front and pointed toward each other.

- Carefully put the fairing on top of the two steel rails. After placing first a 1/4" steel washer and then a 5/16" neoprene washer on the 1/4-28x2 (6x50mm) mounting bolts, insert the mounting bolts through the rails, washers and bushings. Be sure that the rails, washer and bushing holes are aligned. (Illus. 4)

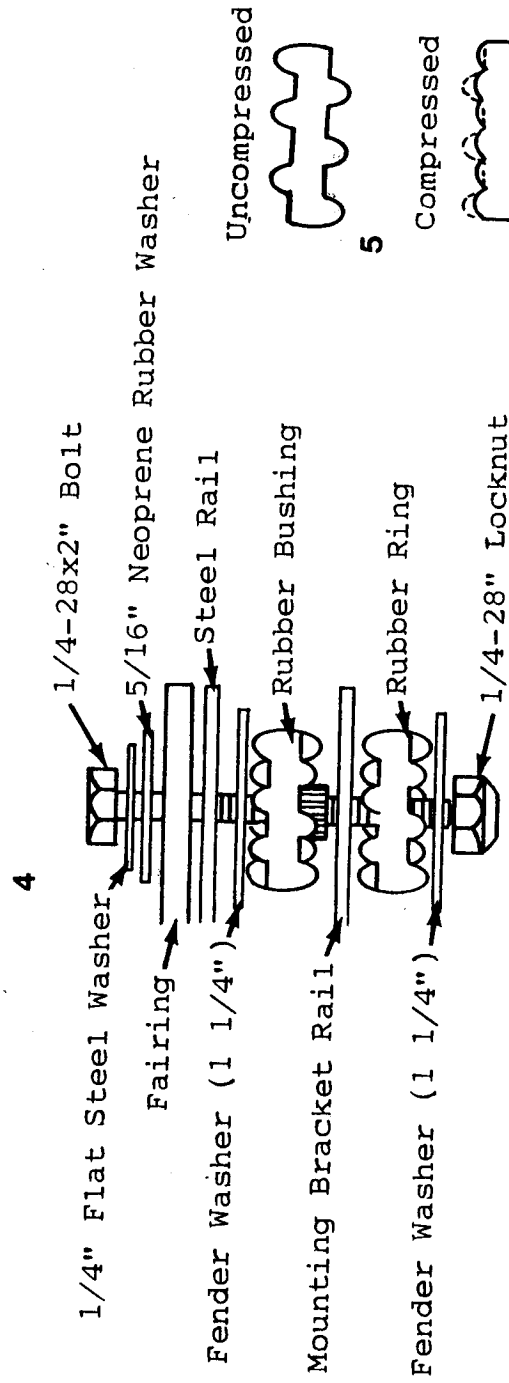

Uncompressed



5

Compressed



- Put a rubber ring, 1 1/4" fender washer and locknut on each mounting bolt, under the mounting bracket. Tighten each mounting bolt until the rings and bushings are compressed as shown. (Illus. 5)
- Fit the reflectors to the mounting clamps with the 6mm nut provided.



6

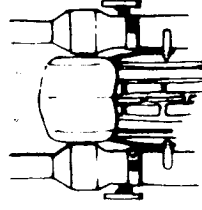

- Install each assembly on the fork slider as shown. (Illus. 6)

Refer to your Owner's Manual for windshield mounting instructions and final adjustments. We suggest you insert these instructions in the manual for future reference.

warning

AFTER INSTALLATION, THE FAIRING OR BRACKET MUST NOT INTERFERE WITH ANY PART OF YOUR MOTORCYCLE. CHECK THE AREA BETWEEN YOUR MOTORCYCLE FORKS AND THE FAIRING FOR CONTACT AT ANY POINT (CABLES, HORNS, ETC.), WHILE TURNING THE HANDLEBARS COMPLETELY FROM SIDE TO SIDE.