

1979-80 KAWASAKI KZ1300

SADDLE BAG HARDWARE KIT #  
 10 006 01 27

Packing List

| PART #       | DESCRIPTION                | QUANTITY |
|--------------|----------------------------|----------|
| 14 012 01 21 | Saddle Bag Owner's Manual  | 1        |
| 15 003 01 28 | Hardware Bag               | 1        |
|              | Upper Mounting Bracket     | 2        |
|              | Turnsignal Bolt            | 2        |
|              | Turnsignal Stalk           | 2        |
|              | Step Washer                | 2        |
|              | 6x20mm Bolt                | 2        |
|              | 8x20mm Bolt                | 4        |
|              | 8x35mm Bolt                | 2        |
|              | 6x30mm Bolt                | 4        |
|              | 6mm Locknut                | 2        |
|              | 8mm Locknut                | 6        |
|              | 6mm Flat Washer            | 8        |
|              | 8mm Flat Washer            | 12       |
|              | 6mm Lock Washer            | 4        |
|              | 12mm Lock Washer           | 2        |
|              | Red Reflector              | 2        |
| 15 003 02 08 | Luggage Rack               | 1        |
|              | Rear Cross Strut           | 1        |
|              | Front Luggage Rack Support | 1        |
|              | Rear Luggage Rack Support  | 1        |
|              | Right SideLoop             | 1        |
|              | Left SideLoop              | 1        |



14 012 01 21  
©Vetter Corp. 1978  
3-20-80

NOTE: Federal legislation requires that this manual be given to the consumer. It contains the customer's copy of the Limited Warranty and includes future reference material.

# Floating Mount Saddle Bags

1979-80  
Kawasaki KZ1300

Owner's Manual  
and Mounting Instructions

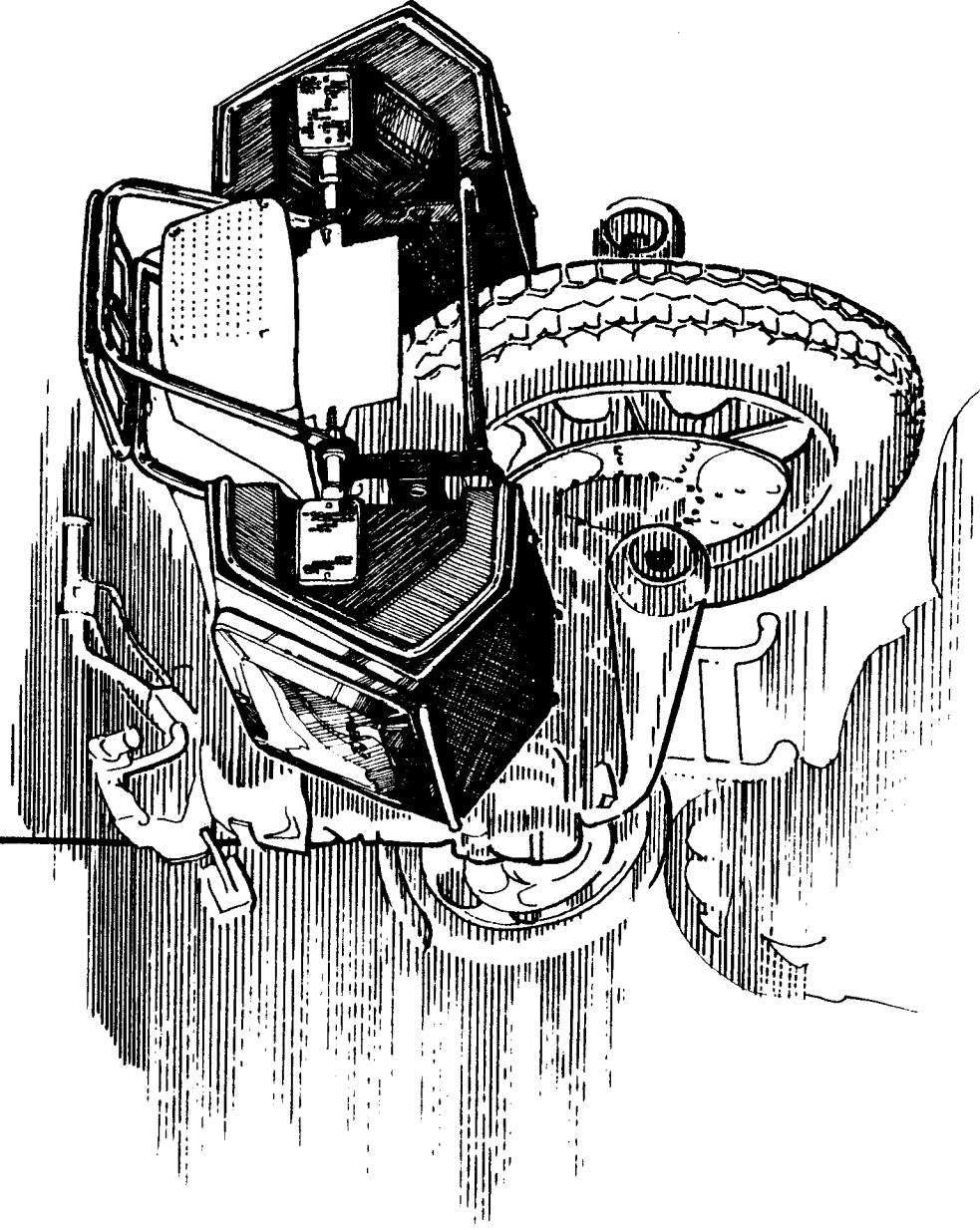

# Table of Contents

|                              |    |
|------------------------------|----|
| INTRODUCTION .....           | 2  |
| RIDING TIPS .....            | 2  |
| PREPARE THE MOTORCYCLE ..... | 3  |
| INSTALL HARDWARE .....       | 5  |
| ASSEMBLE SADDLE BAGS .....   | 6  |
| MOUNT SADDLE BAGS .....      | 7  |
| MAINTENANCE .....            | 10 |
| CUSTOMER SERVICE .....       | 10 |
| WARRANTY .....               | 10 |

# Introduction

This manual contains important information regarding the proper installation, safe use, and maintenance of your Floating Mount Saddle Bags. We urge you to read it completely and follow the recommendations for the most trouble-free and enjoyable use.

Statements preceded by the following words are of special significance. Heed them well!

**WARNING** Means there is the possibility of injury to yourself and others if instructions are not followed.

**CAUTION** Means there is the possibility of damage to the equipment if instructions are not followed.

Look at the Hardware Parts illustration while you unpack the Saddle Bags. You will instantly recognize the various parts and will easily understand the assembly steps that follow. Working straight through the manual will assure that you forget nothing during installation.

As you are following the instructions, double check the following points, as they are critical:

1. Carefully check wiring color codes.
2. If you have safety bars, check carefully to determine if they are compatible with the saddle bag mounting system.
3. Check for clearance and tighten all bolts before operating your motorcycle with the newly installed saddle bags and hardware.
4. Periodically check and retighten all bolts and clamps after installation.

**NOTE:** This manual may cover several motorcycles. Some illustration details may differ from your motorcycle. Follow the instructions.

# Riding Tips

**WARNING** Improper Saddle Bag installation and loading can cause an accident.

Adding to the load your motorcycle will carry requires that you give special attention to several important details: loading, weight of the load, tire and suspension maintenance, and riding technique.

Never overload your motorcycle. Observe the weight limitations posted on the Saddle Bags, and your motorcycle's total payload as shown on the tire information label or in your motorcycle owner's manual. Load the heavier items in the front of the Saddle Bags, and balance the weight between the right and left bags.

Be certain to maintain the tire pressure listed in your owner's manual, and check tires often

Before you head out on the road with your newly installed saddle bags, review the RIDING TIPS given here, and your motorcycle Owner's Manual.

## WARNING

The hardware described in this manual was designed solely to mount the Vetter Floating Mount Saddle Bags to the motorcycle(s) designated on the hardware packing list. Any other application may result in equipment damage or unsafe handling.

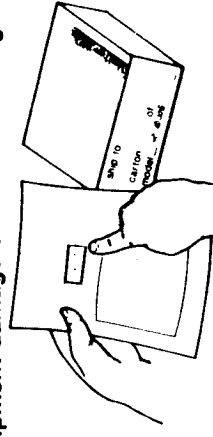

Make sure you have the right hardware for your motorcycle: check the model and year designation on the packing list, then compare the hardware kit number on the packing list with the number on the hardware box. If you or your dealer are unable to determine if this hardware is for your motorcycle, contact the Customer Service Department, Vetter Corporation, Ran-toul, IL 61866 (217) 893-9300

*All information herein is based on the latest product information available at the time of publication. The Vetter Corporation reserves the right to change design and specifications, and/or make additions to or improvements in its products without notice and without incurring any obligation to make such changes in products previously manufactured.*

for wear. Consult your owner's manual for suspension settings. If the rear suspension does not perform adequately under additional weight, and spring adjustment doesn't help, you may want to fit stronger shock absorbers. See your dealer for recommendations.

Finally, adapt your riding style to minimize the effects of the added weight on your motorcycle's chassis. Avoid sudden, full throttle openings when starting from a standstill or while negotiating turns. Carefully coordinate the application of the front and rear brakes. And allow yourself enough orientation time before heading out into traffic or on a long ride.

Thank you for buying Vetter products. We appreciate your business and comments.

The Vetter Corporation

# Prepare the Motorcycle

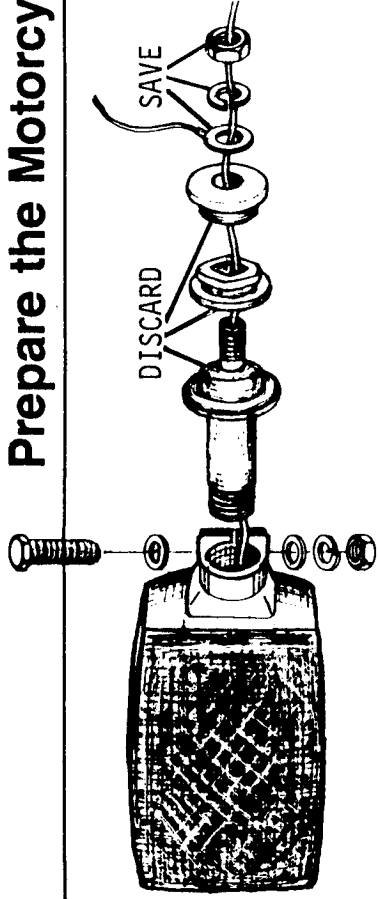

# 1

## Prepare the Motorcycle

Open the seat.  
Remove the rear cowling.

**Disconnect Turnsignals**  
Disconnect the rear turnsignal wires.

Remove the rear turnsignals from their stalks. Remove the stalks from the bike. Save the hardware for reinstallation.

Remove tail light assembly mounting bolts (4).

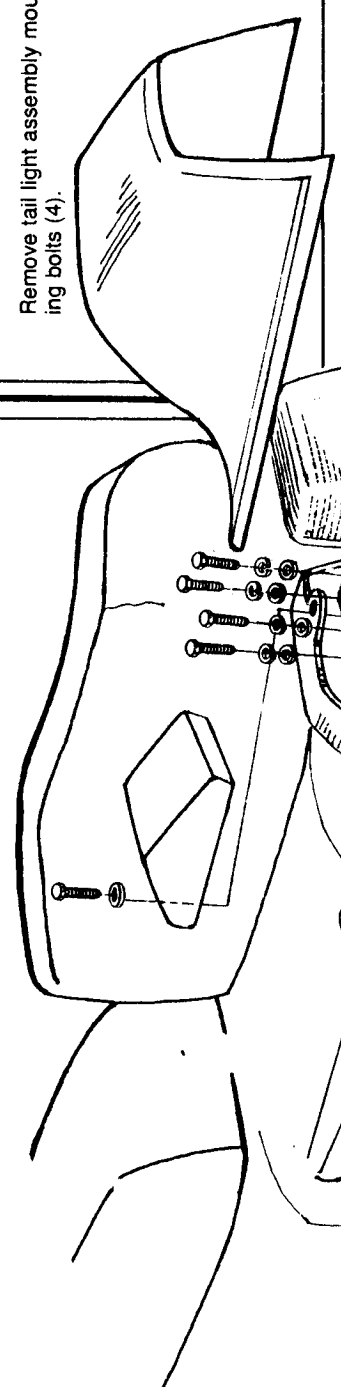

# 2

## Remove Passenger Footrests

Remove the passenger footrests. Save the hardware for reinstallation.

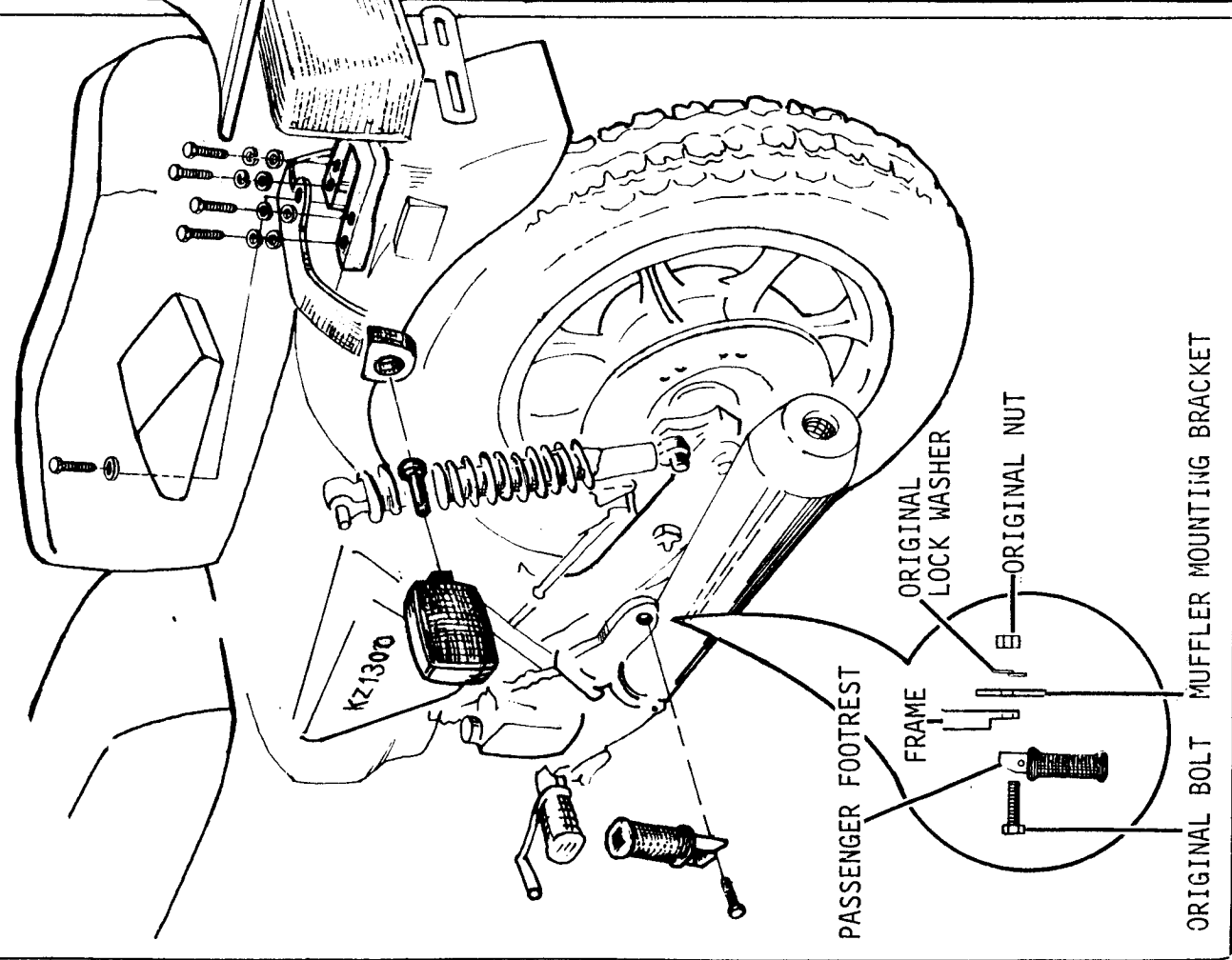

# Hardware Parts

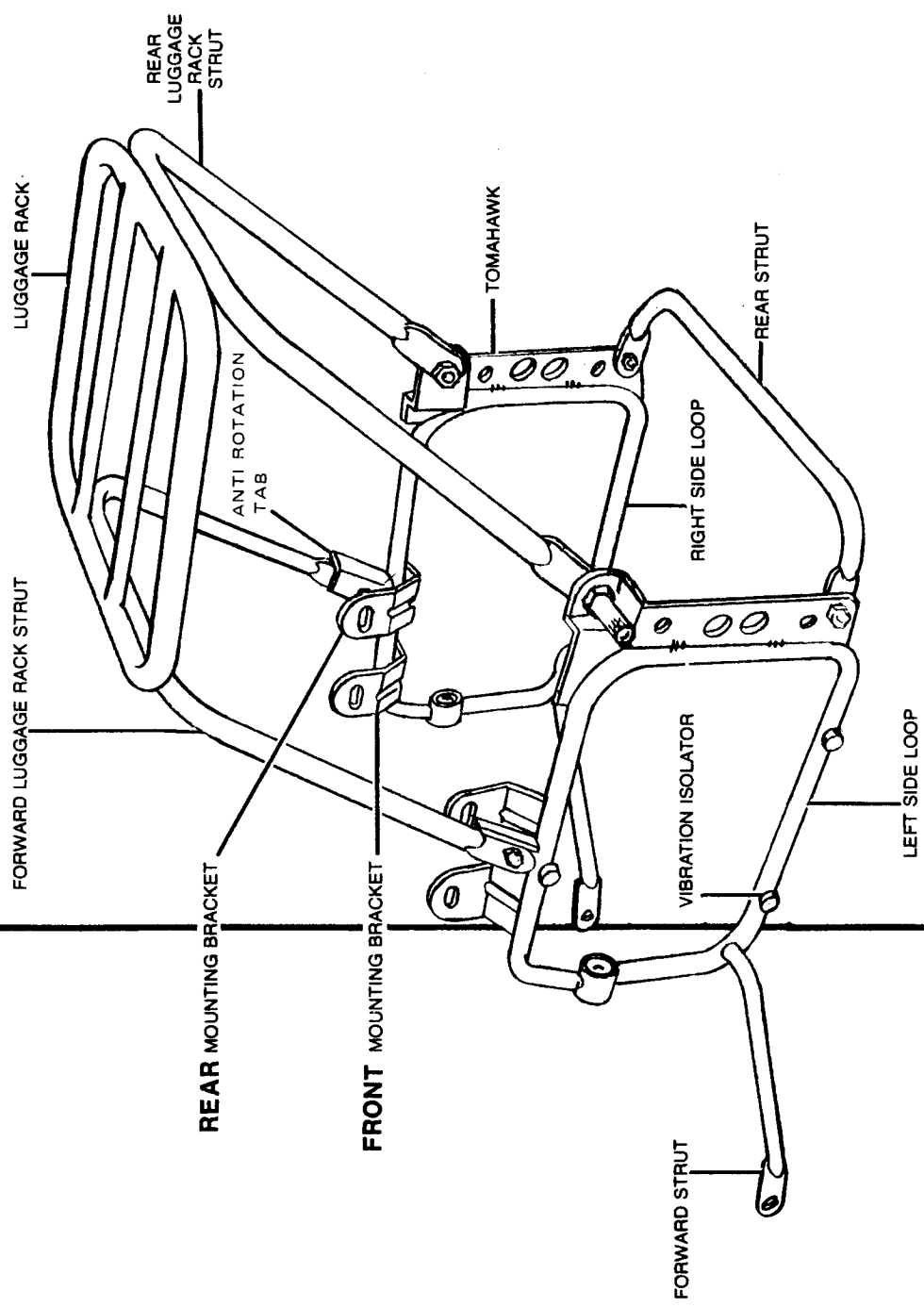

STEP WASHER

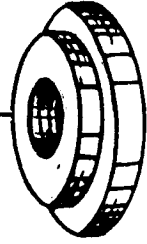

URNSIGNAL STALK

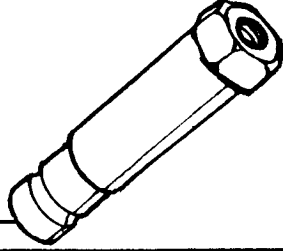

URNSIGNAL BOLT



UPPER MOUNTING BRACKET

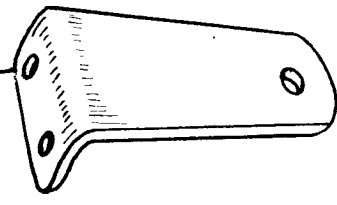

USE THIS SCALE TO CHECK BOLT AND WASHER DIMENSIONS

Metric Scale  
mm



# Install Hardware

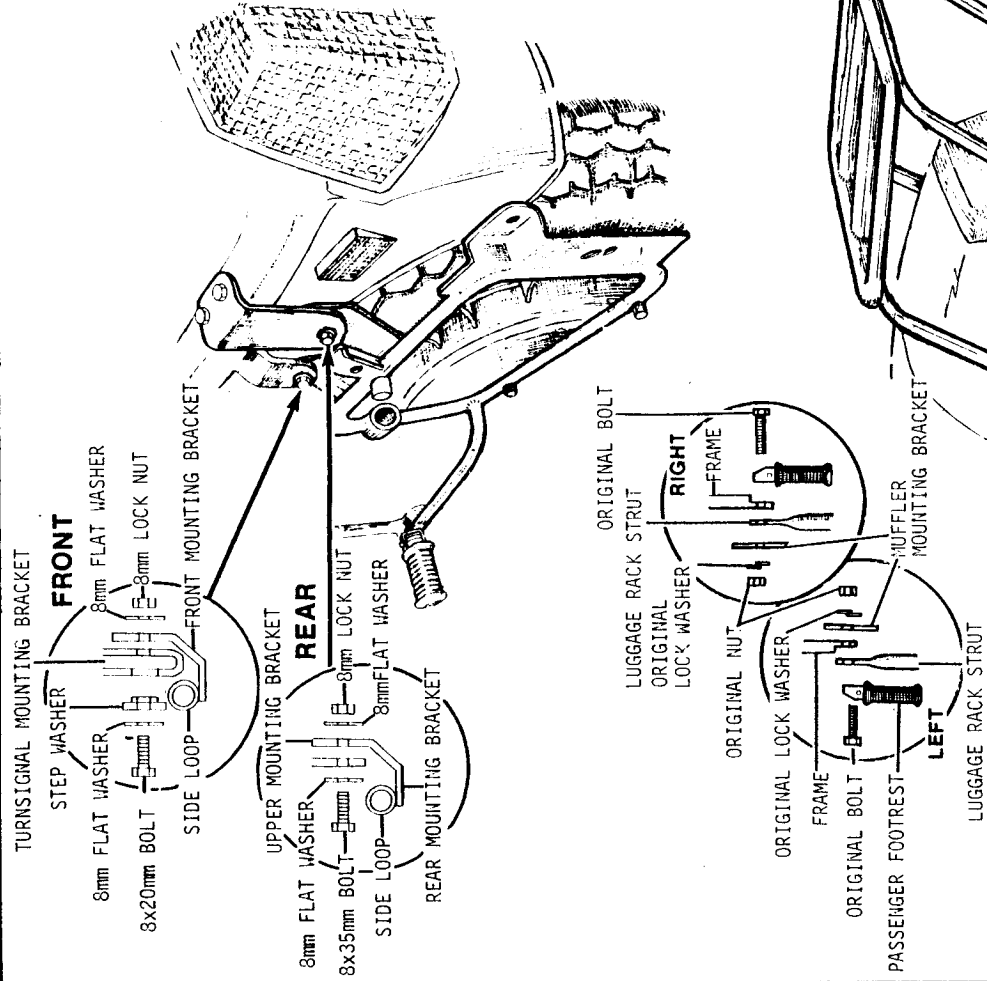

# 1

## Mount Side-loop

Install the upper mounting brackets at the tail light assembly mounting bolt locations using the original bolts, lock washers, flat washers and lock-nuts.

Position and mount the side-loops at the rear mounting tab, inside the upper mounting tab, inside the upper mounting bracket using the provided 2-8x20mm bolts, 4-8mm flat washers, 2-step washers and 2-locknuts as shown.

Tighten all mounting bolts and nuts. Close the seat.

Position and mount the side-loops at the upper mounting tab, outside the mounting bracket.

Reinstall the footrests and mount the forward struts as shown. (Right side — inside muffler bracket — Left side outside frame bracket, between footrest and bracket) Install the rear cross strut.

# 2

## Install Luggage Rack

Install the rear luggage support with provided turnsignal stalks as shown. Be sure the holes for the luggage rack are pointing upward.

Thread the turnsignal wiring through the stalks. Install the turnsignals on the stalks. Reconnect the wires at their original connections.

Reinstall the rear cowl.

Mount the luggage rack to the front luggage rack strut.

Install the front luggage rack strut to the anti-rotation tabs.

Mount the luggage rack to the rear luggage rack strut.

Mount the supplied reflectors.

In order to supply saddle bags of various colors, the doors are packaged separately and require a simple mounting procedure before the bags are ready for use.

Separate left and right saddle bags, doors and Texas Trim. Assemble one bag at a time.

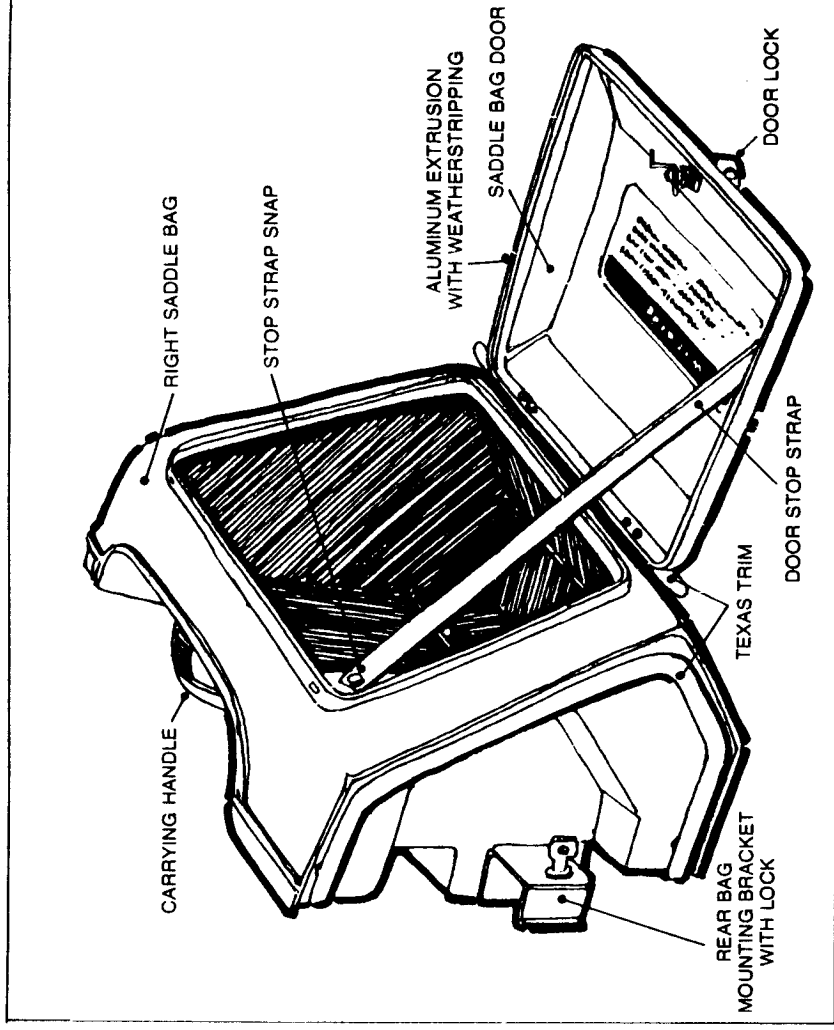

## Assemble Saddle Bags

### 1 Mount rear Texas Trim and side trim

Attach the rear Texas Trim using three 10-32 x 7/8 screws and black nylon washers inside the bag, with black spacers outside the bag.

Mount the door and side trim with four 4 x 14mm screws and lock nuts. Connect the door stop straps.

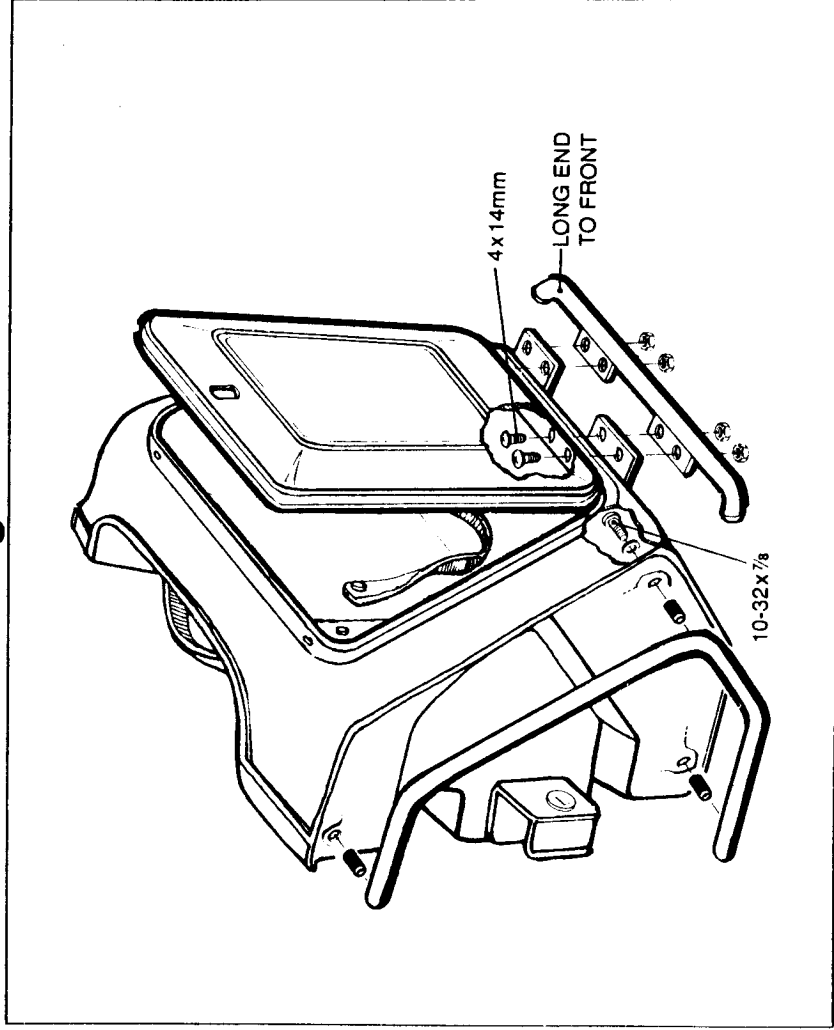



# 2

## Mount door lock and adjust

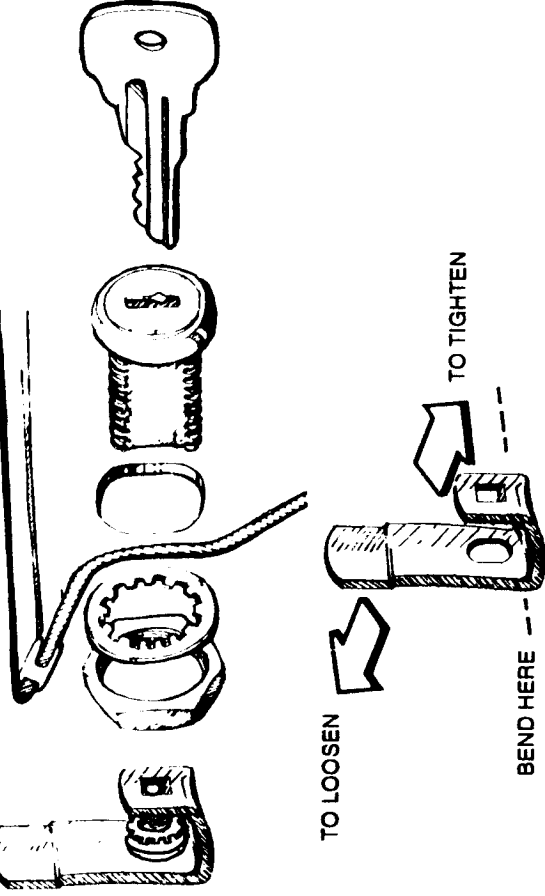

Assemble the lock in the order shown. Do not overtighten the large nut.

When locking the door, there should be moderate resistance to key movement. If the locking action is too tight or too loose, adjust the locking cam by bending it as shown.

This adjustment may also be required after long-term use.

# 3

## Mount Saddle Bags

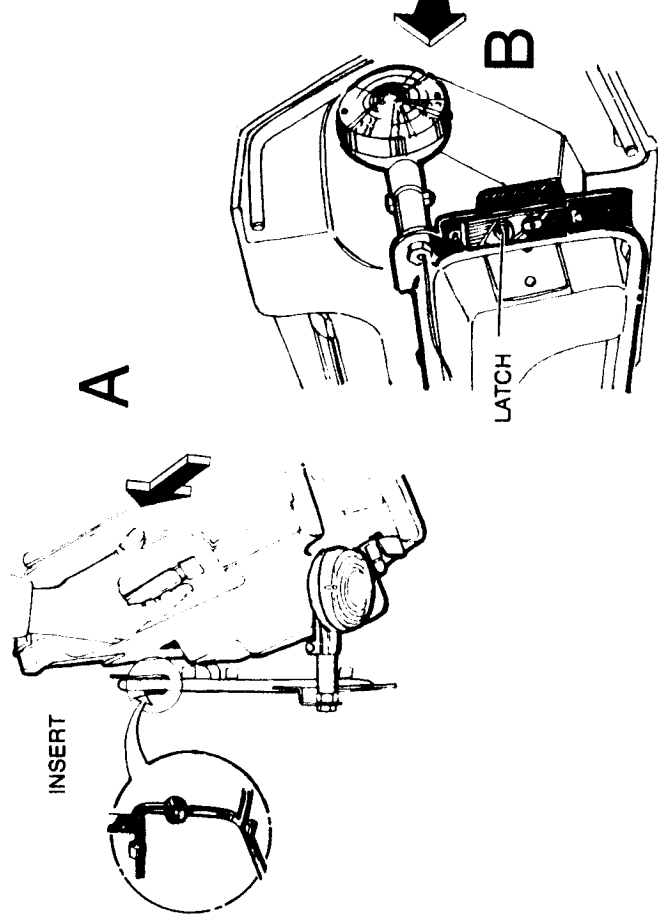

Insert the front mounting stud into the stud funnel, then push the rear conehead into its spring loaded receptacle. (You'll hear a "click" when the conehead seats.)

### CAUTION

Saddle Bag may fall off if not properly latched.

Remove key from lock before installation Saddle Bags.

Push rear latch into retainer until it clicks.

Test latching-pull outward on the Saddle Bags.

## 4 Check bag/muffler clearance

### CAUTION

To avoid saddle bag damage from muffler heat, a minimum clearance of 19mm (3/4") is needed with stock exhaust systems. Non-stock exhaust systems require exhaust systems require 25.4mm (1") clearance because they may run hotter. Hot exhaust gases must not be directed toward the saddle bag.

After hardware installation, shock adjustment could be difficult. To provide adequate work space, first remove Saddle Bags and/or anything from the luggage rack. Disconnect forward mounting strut from frame and rotate hardware assembly out of the way.

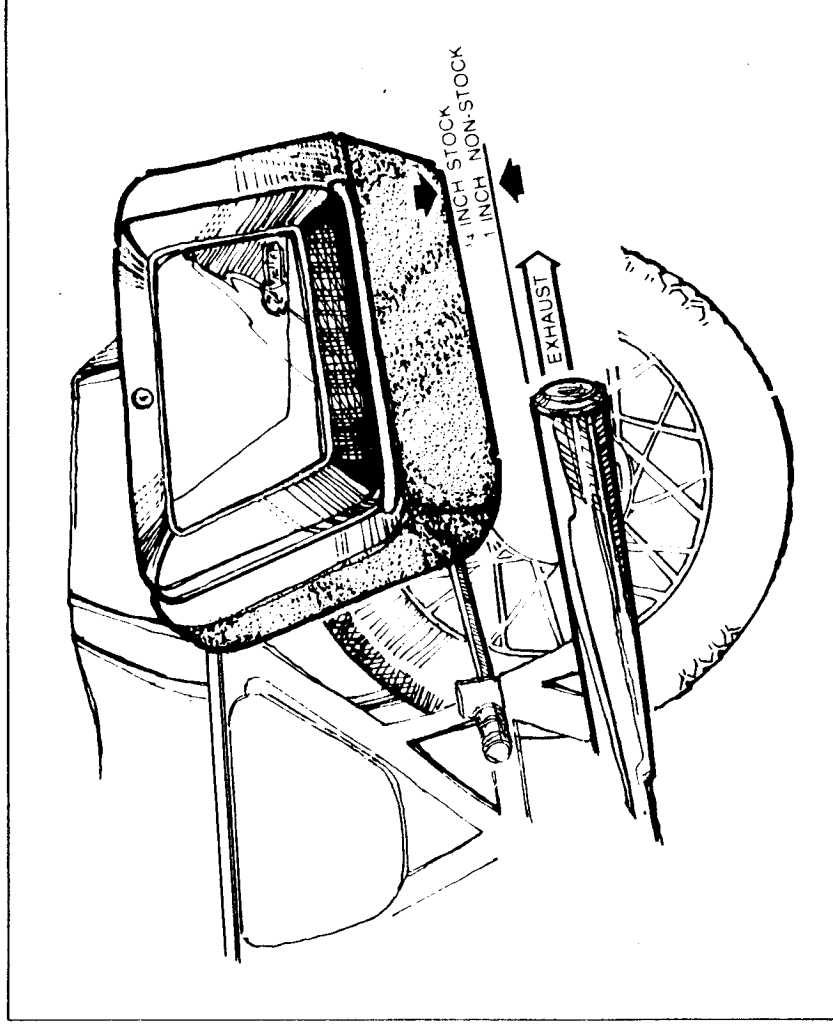

## 5 Removal/Carrying

To remove the bag, simply turn the key to its release position, and pull the rear of the bag out and back to disengage the forward mount.

NOTE: If the conehead and/or latch mechanism become difficult to operate, a thin layer of light grease on the parts should correct the problem.

NOTE: Use only powdered graphite in the locks themselves for lubricant.

When carrying the saddle bags by hand, they are designed to be carried with the doors facing you.

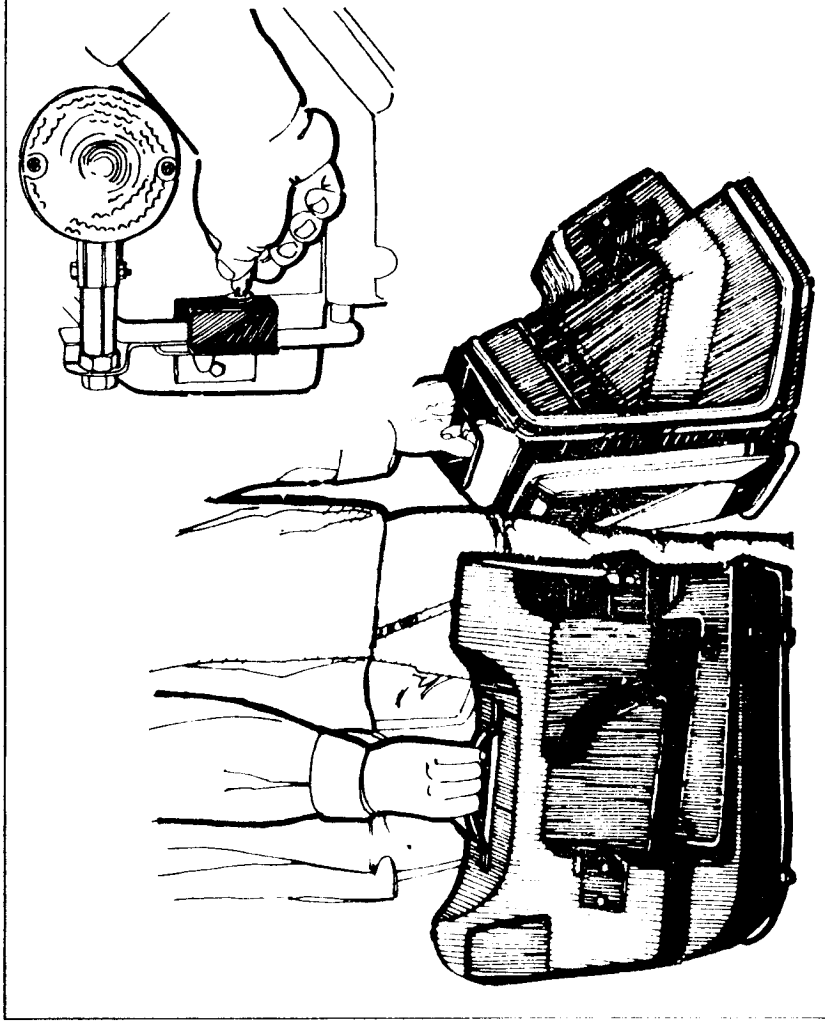

# WARNING

**READ CAREFULLY  
BEFORE LOADING**

**DO NOT EXCEED  
MAXIMUM LOAD**

| EACH SADDLE BAG | TAIL TRUNK** | LUGGAGE RACK<br>W/O TAIL TRUNK | TOTAL       |
|-----------------|--------------|--------------------------------|-------------|
| 20LB (9KG)      | 20LB (9KG)   | 20LB (9KG)                     | 60LB (27KG) |

 THE SADDLEBAGS, TAIL TRUNK, AND LUGGAGE RACK ARE FOR LIGHT WEIGHT ITEMS. EXCESSIVE WEIGHT AND IMPROPER LOADING MAY AFFECT MOTORCYCLE STABILITY, DECREASE SAFE OPERATING SPEED, AND CAUSE MOUNTING HARDWARE OR LUGGAGE FAILURE.

 FACTORS BEYOND OUR CONTROL SUCH AS OPERATOR'S WEIGHT, PASSENGER'S WEIGHT, WEIGHT OF OTHER ACCESSORIES, ETC. MAY FURTHER REDUCE THE SAFE AMOUNT OF WEIGHT CARRIED IN OUR SADDLEBAGS AND TAIL TRUNK OR ON THE LUGGAGE RACK.

 DISTRIBUTE THE LOAD EQUALLY ON BOTH SIDES OF THE MOTORCYCLE TO MINIMIZE IMBALANCE.

 DO NOT EXCEED YOUR MOTORCYCLE'S VEHICLE CAPACITY LOAD LIMIT AS SHOWN ON ITS TIRE INFORMATION LABEL AND IN YOUR MOTORCYCLE OWNER'S MANUAL.

 REFER TO THE INSTALLATION INSTRUCTIONS FOR ADDITIONAL INFORMATION. IF YOU HAVE ANY QUESTIONS CONTACT YOUR DEALER. IF HE IS NOT AVAILABLE, CONTACT:

CUSTOMER SERVICE DEPT.  
VETTER CORPORATION  
Rantoul, IL 61866 (217) 893-9300

# Troubleshooting and Maintenance

## ELECTRICAL

If your problem is electrical, check your color code to insure the proper wires have been connected. A loose bullet connector connection can be improved by unplugging the connector and making the female receptacle smaller by use of pliers and then reinstalling the bullet connector. If your turn signals do not function properly, your ground connection is probably not making good contact, or your battery is weak and needs to be serviced.

If there are any problems that cannot be solved by you or your dealer, contact the Customer Service Department of Vetter Corporation, Rantoul, IL 61866 (217) 893-9300.

## MOUNTING

The best answer to almost any problem is to reread your instructions carefully. Sometimes it is helpful for someone else to look the problem over, especially someone who has not been working on the installation with you, such as your dealer.

## MAINTENANCE

The Floating Mount Saddle Bags require little maintenance, but we recommend that you make periodic checks. The mounting bolts and mounting clamps should be rechecked for tightness and adjustments made as necessary.

**Cleaning and waxing the Saddle Bags:** When washing your saddle bags, use a mild detergent and warm water. Washing should be done with a soft cloth or a sponge. Avoid spraying water under pressure directly at the joint between the door and the body of the saddle bag as some water may enter the bag itself. Waxing the saddle bags is easy; furniture polish works as well as anything we have found. Spray the polish on a rag rather than on the bag itself, however, as if it is sprayed on the bag the wax becomes very difficult to remove from the bag's textured surface.

**CAUTION**

**Do not use cleansers which contain methyl or ethyl alcohol.**

**CAUTION**

**Hydraulic brake fluid will damage your saddle bags. Never allow it to come in contact with your saddle bags.**

With normal use the bodies of your saddle bags may become scratched or marred. Small cosmetic touch-ups can be accomplished by treating the area with a hot air gun (a hair dryer is not hot enough) or a propane torch. Using either the torch or the hot air gun, pass back and forth over the marred area in a sweeping motion at a safe distance from the bag surface. The correct amount of heat will smooth and restore shine to the damaged area. If the area in concern is located near the door or a painted part, that part should be removed before any treatment is performed.

## Limited Warranty — Vetter Corporation Products

This warranty applies to products manufactured or distributed by Vetter Corporation, Rantoul, IL 61866 (217) 893-9300, and sold by Vetter Corporation or its authorized dealers within the United States, Puerto Rico, and the Virgin Islands. **It is given to the first retail purchaser only** and is not transferable to subsequent owners.

**Warranty Obligation:** Vetter Corporation warrants that it, or one of its authorized dealers, will repair or, at its option, replace any part proven to be defective in factory material or workmanship within six (6) months (unlimited mileage) of the date of purchase. Parts repaired or replaced under this warranty are warranted only during the balance of the original warranty period. **THIS WARRANTY DOES NOT INCLUDE ANY LABOR CHARGES FOR TROUBLESHOOTING, REMOVAL OR INSTALLATION.**

**Exclusions from Coverage:** 1. Any repairs or replacements necessitated by misuse, negligence, fire, accident, damage caused by exposure to gasoline, brake fluid, harmful solvents and cleaners, paints, or repair material, use of unauthorized accessories, faulty installation, or installation upon motorcycles or vehicles not listed in Vetter Corporation's retail and dealer catalog sheets, or improper or unreasonable maintenance are not covered. 2. This warranty does not cover "toes" rainboots. **DISCLAIMER OF CONSEQUENTIAL DAMAGES AND LIMITATIONS OF IMPLIED WARRANTIES: TO THE EXTENT THE LAW PERMITS, VETTER CORPORATION SHALL NOT BE LIABLE UNDER ANY CIRCUMSTANCES FOR LOSS OF USE OF THE PRODUCT, CONSEQUENTIAL OR INCIDENTAL DAMAGES, ANY IMPLIED WARRANTY ARISING UNDER LAW, INCLUDING THOSE OF**

## PAINTING INSTRUCTIONS

If you wish to repaint your saddle bag doors, we recommend that the following instructions be used:

1. Remove the Vetter nameplate and stripe decals.
2. Sand thoroughly with 320 grit wet sandpaper.
3. Resand with 400 grit wet sandpaper
4. Dry thoroughly
5. Spray with Dupont 100S Multi-Purpose Primer
6. Spray Dupont Weight Lifter Acrylic Enamel with 792S or 793S Hardener.
7. Install new vinyl decals.

## SADDLE BAG STRIPING

When removing striping from the saddle bag doors, the suggested method is to use 3M Woodgrain and striping Remover, part number 08907, followed by 3M Adhesive Remover, part number 08908. Please follow the direction on the spray cans. These products can be obtained from your Vetter dealer or at most paint and automotive stores that carry 3M products.

When handling saddle bag striping, do not crease or bend it. Do not pull the backing paper off the striping with the expectation of reapplying. Backing paper will NOT restick.

If you have any questions on storing, handling, removing or applying of saddle bag striping that your dealer cannot answer, contact our Customer Service Department.

## REPLACEMENT PARTS

We recommend that you always use Genuine Vetter Replacement Parts. Contact your local Vetter dealer to purchase or order replacement parts.

## CUSTOMER SERVICE

Any problems concerning installation of the Saddle Bags should be referred to your dealer or the Customer Service Department, Vetter Corporation, Rantoul, IL 61866. We are here to serve you: (217) 893-9300. In order to provide the maximum amount of service to you and the dealer, it is necessary that you fill out the Owner's Registration Card and promptly return it to Vetter Corporation. We also suggest you record your saddle bags Serial number here:

\_\_\_\_\_ so you'll have it should you ever need to contact us: (It is located inside the left hand saddle bag.)

Also record your key number here: \_\_\_\_\_ so that you can order replacement keys and locks if necessary.

**MERCHANTABILITY AND FITNESS FOR A PARTICULAR PURPOSE, IS LIMITED TO THE DURATION OF THIS LIMITED WARRANTY.**

**IMPORTANT:** Some states do not allow limitations or exclusions or consequential or incidental damages, so the above limitations may not apply to you.

**To Obtain Warranty Service:** Information you must provide when filing claim. 1. Name, mailing address and telephone number. 2. Selling dealer's name and address. 3. Serial number on serialized product. 4. Model and year of motorcycle. 5. Date product was purchased. 6. Date and mileage at failure. 7. Description of problem.

**Steps to take:** 1. Contact or take your product to an authorized Vetter dealer (preferably your selling dealer) at your expense. 2. If you are unable to obtain warranty service, or should your warranty claim be denied for reasons that you consider unjustifiable, contact the dealership owner. Normally, this should resolve your problem. However, if you require further assistance, write or call the Customer Service Department of Vetter Corporation, Rantoul, ILL 61866, (217) 893-9300. At this point, you must be prepared to return the part in question to Vetter Corporation with all freight charges prepaid. The charges will be reimbursed to you if they total over \$5.00 (five dollars) and the warranty claim is honored. This warranty gives you specific legal rights and you may also have other rights which vary from state to state.